

NAPCO Series 8000DH

CO₂ Incubator

Direct Heat with Sterilization Cycle

Operating and Maintenance Manual

7003584 Rev. 0

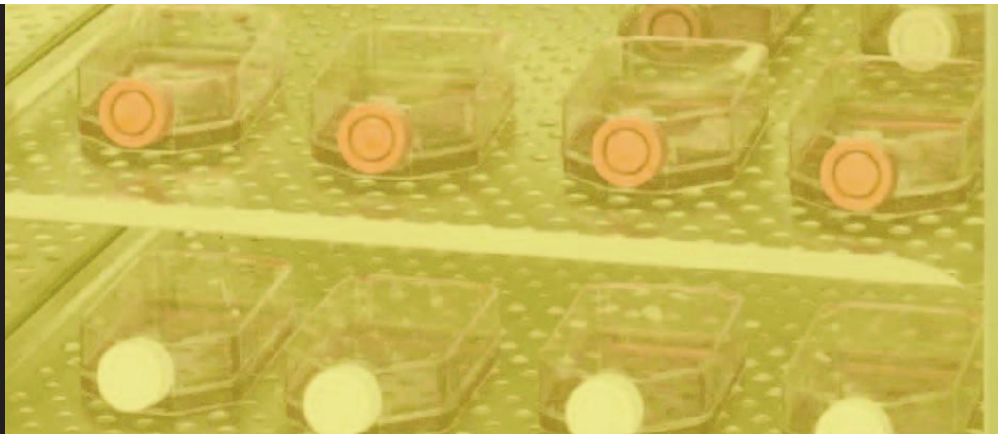

Analyze • Detect • Measure • Control™

Thermo
ELECTRON CORPORATION

Model	Sensor*	Voltage**	RH Display
3598	T/C	115	No
3599	IR	115	No
3584	T/C	115	Yes
3585	IR	115	Yes

*T/C is a thermal conductivity sensor. IR is an infra-red sensor.

**All units are 50/60 Hz.

MANUAL NUMBER 7003584

0	--	7/14/06	Original manual	CCS
REV	ECR/ECN	DATE	DESCRIPTION	By



Important Read this instruction manual. Failure to read, understand and follow the instructions in this manual may result in damage to the unit, injury to operating personnel, and poor equipment performance. ▲

Caution All internal adjustments and maintenance must be performed by qualified service personnel. ▲

Material in this manual is for information purposes only. The contents and the product it describes are subject to change without notice. Thermo Electron Corporation makes no representations or warranties with respect to this manual. In no event shall Thermo be held liable for any damages, direct or incidental, arising out of or related to the use of this manual.

Warning If the incubator is not used in the manner specified in this operating manual, the protection provided by the equipment design may be impaired. ▲

©2006 Thermo Electron Corporation. All rights reserved.



Important operating and/or maintenance instructions. Read the accompanying text carefully.



Potential electrical hazards. Only qualified persons should perform procedures associated with this symbol.



Equipment being maintained or serviced must be turned off and locked off to prevent possible injury.



Hot surface(s) present which may cause burns to unprotected skin, or to materials which may be damaged by elevated temperatures.



Marking of electrical and electronic equipment, which applies to electrical and electronic equipment falling under the Directive 2002/96/EC (WEEE) and the equipment that has been put on the market after 13 August 2005.



This product is required to comply with the European Union's Waste Electrical & Electronic Equipment (WEEE) Directive 2002/96/EC. It is marked with the WEEE symbol. Thermo Electron has contracted with one or more recycling/disposal companies in each EU Member State European Country, and this product should be disposed of or recycled through them. Further information on Thermo Electron's compliance with this directive, the recyclers in your country and information on Thermo Electron products will be available at www.thermo.com.

- ✓ Always use the proper protective equipment (clothing, gloves, goggles, etc.)
- ✓ Always dissipate extreme cold or heat and wear protective clothing.
- ✓ Always follow good hygiene practices.
- ✓ Each individual is responsible for his or her own safety.

Do You Need Information or Assistance on Thermo Electron Corporation Products?

If you do, please contact us 8:00 a.m. to 6:00 p.m. (Eastern Time) at:

1-740-373-4763	Direct
1-888-213-1790	Toll Free, U.S. and Canada
1-740-373-4189	FAX
http://www.thermo.com	Internet Worldwide Web Home Page
services.controlenv@thermo.com	Service E-Mail Address

Our Sales Support staff can provide information on pricing and give you quotations. We can take your order and provide delivery information on major equipment items or make arrangements to have your local sales representative contact you. Our products are listed on the Internet and we can be contacted through our Internet home page.

Our Service Support staff can supply technical information about proper setup, operation or troubleshooting of your equipment. We can fill your needs for spare or replacement parts or provide you with on-site service. We can also provide you with a quotation on our Extended Warranty for your Thermo products.

Whatever Thermo products you need or use, we will be happy to discuss your applications. If you are experiencing technical problems, working together, we will help you locate the problem and, chances are, correct it yourself...over the telephone without a service call.

When more extensive service is necessary, we will assist you with direct factory trained technicians or a qualified service organization for on-the-spot repair. If your service need is covered by the warranty, we will arrange for the unit to be repaired at our expense and to your satisfaction.

Regardless of your needs, our professional telephone technicians are available to assist you Monday through Friday from 8:00 a.m. to 6:00 p.m. Eastern Time. Please contact us by telephone or fax. If you wish to write, our mailing address is:

Thermo Electron Corporation
Controlled Environment Equipment
Millcreek Road, PO Box 649
Marietta, OH 45750

International customers, please contact your local Thermo Electron distributor.

Warranty Notes

Information You Should Know Before Requesting Warranty Service

- **Locate the model and serial numbers.** A serial tag is located on the unit itself.
- For equipment service or maintenance, or with technical or special application inquiries, contact Technical Services at 1-888-213-1790 or 1-740-373-4763 (USA and Canada). Outside the USA, contact your local distributor.

Repairs NOT Covered Under Warranty

- **Calibration of control parameters.** Nominal calibrations are performed at the factory; typically $\pm 1^{\circ}\text{C}$ for temperature, $\pm 1\%$ for gases, and $\pm 5\%$ for humidity. Our service personnel can provide precise calibrations as a billable service at your location. Calibration after a warranty repair is covered under the warranty.
- **Damage resulting from use of improper quality water, chemicals or cleaning agents detrimental to equipment materials.**
- **Service calls for improper installation or operating instructions.** Corrections to any of the following are billable services:
 - 1) electrical service connection
 - 2) tubing connections
 - 3) gas regulators
 - 4) gas tanks
 - 5) unit leveling
 - 6) room ventilation
 - 7) adverse ambient temperature fluctuations
 - 8) any repair external to the unit
- **Damage resulting from accident, alteration, misuse, abuse, fire, flood, acts of God, or improper installation.**
- **Repairs to parts or systems resulting from unauthorized unit modifications.**
- **Any labor costs other than that specified during the parts and labor warranty period, which may include additional warranty on CO₂ sensors, blower motors, water jackets, etc.**

Table of Contents

Section 1	Installation and Start-Up	1-1
	Keypad Operation	1-3
	Displays	1-4
	Installing the Incubator	1-4
	Stacking the Incubators	1-5
	Preliminary Cleaning	1-6
	Shelf Installation	1-7
	Access Port Filter & CO ₂ Sensor Cover Plate	1-8
	Air Sample Filter Installation	1-8
	HEPA Filter Installation	1-9
	Leveling the Unit	1-9
	Electrical Power Connection	1-9
	Filling the Humidity Pan	1-10
	Connecting the CO ₂ Gas Supply	1-11
	Incubator Start-Up	1-12
Section 2	Calibration	2-1
	Temperature	2-1
	Thermal Conductivity CO ₂ System	2-2
	Infrared CO ₂ System	2-3
	Relative Humidity	2-4

Section 3	Configuration	3-1
	Turn Audible Alarm ON/OFF	3-1
	New HEPA Filter	3-1
	Set REPLACE HEPA filter reminder	3-2
	Set Access Code	3-2
	Set Low Temp Alarm Limit (tracking alarm)	3-3
	Enable Low Temp Alarm to Trip Contacts	3-3
	Set Low CO ₂ Alarm Limit (tracking alarm)	3-4
	Set High CO ₂ Alarm Limit (tracking alarm)	3-4
	Enable CO ₂ Alarms to Trip Contacts	3-5
	Set New Zero Number for T/C CO ₂ Sensors	3-5
	Set New Span Number for T/C CO ₂ Sensors	3-6
	Setting a Low RH Alarm Limit	3-6
	Enable RH Alarms to Trip Contacts	3-7
	Enabling Temp/RH to be Displayed	3-7
Section 4	Alarms	4-1
	Temp Controller Failure TMP CNTR ERR	4-2
	Sensor Fault Alarms	4-2
Section 5	Routine Maintenance	5-1
	Clean Cabinet Exterior	5-2
	Clean Glass Doors	5-3
	Clean Humidity Pan	5-3
	HEPA Filter Maintenance	5-5
	Replace Power Fuses	5-5
	Replace Air Sample Filter	5-6
	Electronics Section	5-6
	Sterilization Cycle	5-8

Section 6 Factory Options6-1
 Remote Alarms6-1
 Humidity Readout (P/N 1900091)6-2

Section 7 Specifications7-1

Section 8 Spare Parts8-1
 Exploded Part Drawings8-2

Section 9 Electrical Schematics9-1

Section 10 Warranty Information10-1

Section 1 Installation and Start-Up

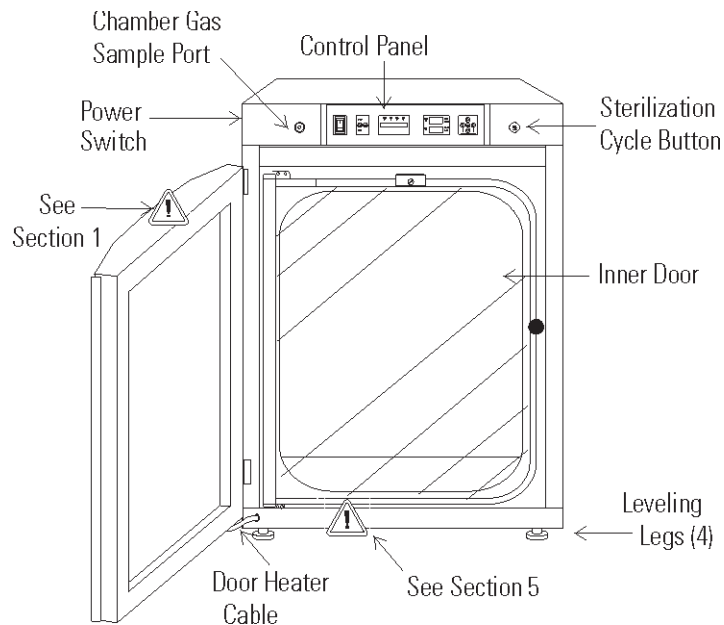

Figure 1-1. Components

- Chamber Gas Sample Port - Used for sampling chamber CO₂ content using a FYRITE or similar instrument.
- Main Power Switch - Mains Disconnect
- Control Panel - Keypad, displays & indicators (Figure 1-2)
- Leveling Legs - Used to level the unit
- Sterilization Cycle Button - Switch to initiate sterilization cycle

Note The incubators are stackable. Information follows. ▲

- ☐ - Mutes the audible alarm.
- Alarm Indicator - Light pulses on/off during an alarm condition.
- MODE** Select Switch - Used to select Run, Setpoints, Calibration and Configuration modes.
- Message Display - Shows system status.
- Mode Select Indicators -
 - RUN: Run Menu
 - SET: Set Points Menu
 - CAL: Calibration Menu
 - CON: Configuration Menu
- HEAT** Indicator - Lights when heaters are activated.
- INJ** Indicator - Lights during CO₂ injection into chamber.
- T (°C) Display - Programmable to display temperature. See Configuration section.
- RH (%) Display - Shows percentage of humidity. See Configuration section.
- CO₂ (%) Display - Programmable to display CO₂ percentage. See Configuration section.
- Arrow Keys (Scroll for Parameters) - Increases or decreases number values, toggles between mode choices.
- ENTER** - Stores the selected value into unit memory.

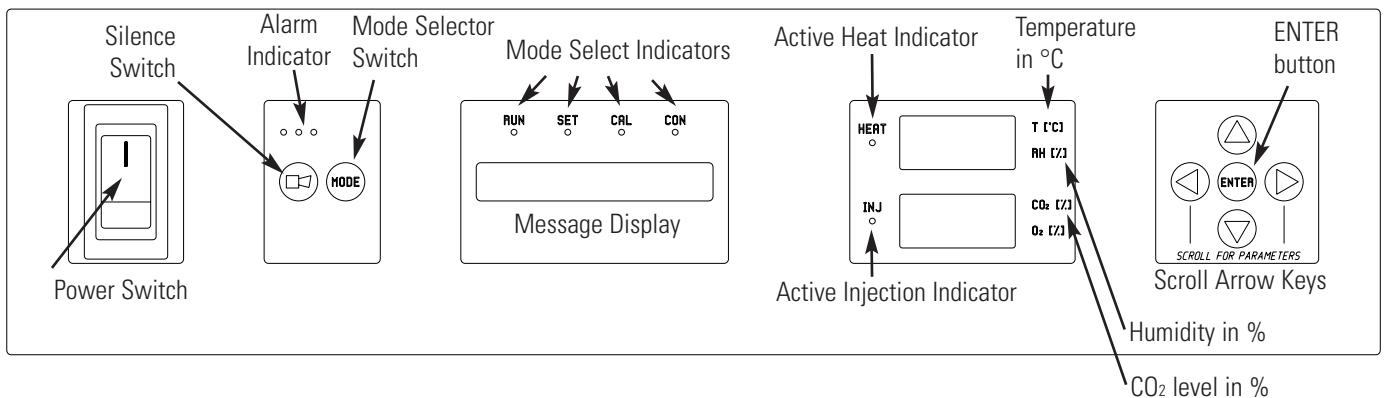

Figure 1-2. Control Panel

Keypad Operation

The 8000DH Series incubator has four basic modes for incubator setup: Run, Setpoints, Calibration and Configuration.

- Run is the default mode for normal operation.
- Set is used to enter system setpoints for incubator operation.
- Calibration is used to calibrate various system parameters.
- Configuration allows for custom setup of various options.

Table 1-1. Selections Under Each Mode

RUN	SETPOINT	CALIBRATION	CONFIGURATION
Default Mode	Temperature Overtemp CO ₂	Temp Offset CO ₂ Cal ¹ IR Cal ² <i>RH Cal</i>	Audible New HEPA Timer Replace HEPA Reminder Access Code Temp Lo Alarm Temp Relay CO ₂ Lo Alarm CO ₂ Hi Alarm CO ₂ Relay CO ₂ Z & S #'s * <i>RH Lo Alarm</i> <i>RH Relay</i> <i>Display Temp</i> <i>Display RH</i>
		Base Unit Displays <i>Option Unit Displays</i>	

¹ T/C units
² IR units
*T/C units only

Keypad Operation (continued)

SCROLL FOR PARAMETERS Arrows: Steps the operator through parameters of SET, CAL and CON modes. The right arrow goes to the next parameter, the left arrow returns to the previous parameter.

Up/Down Arrows: Increases/decreases or toggles the parameter value selected in SET, CAL, and CON modes.

ENTER: Must press this key to save-to-memory all changed values.

 **Key:** Press to mute audible alarm. See Section 4 for alarm ringback times.

Displays

Message Display: Shows system status (Mode) at all times. Shows 'CLASS 100' or 'SYSTEM OK' during normal operation, or alarm messages if the system detects an alarm condition (see Section 4, Alarms). The message 'CLASS 100' is a timing mechanism indicating that, under normal operating conditions with the HEPA filter installed, the air inside the chamber meets the Class 100 air cleanliness standard for particulates of 0.5 micron size or larger per cubic foot of air. Further information on the Class 100 classification of air quality is available from Thermo.

Upper and Lower Displays: The 7 segment upper display shows temp and RH. The lower display shows CO₂ and O₂.

Installing the Incubator

1. Maintain a minimum three inch clearance behind the incubator for electrical and gas hook-ups. In addition, a three inch ventilation space is needed on each side.
2. Locate the unit on a firm level surface capable of supporting the unit weight of 260 lbs (118kg).
2. Locate the unit away from doors and windows and heating and air conditioning ducts.
3. Lift the unit by the sides of the cabinet base. Do not attempt to lift it by the front and back. This places stress on the outer door hinges.

Stacking the Incubators

Warning Install stacked units against a wall or similar structure. ▲

Warning With incubators in a stacked configuration, do not leave both exterior doors open at the same time. ▲

Warning If the units have been in operation, turn them both off and disconnect the power source before beginning any service work. ▲

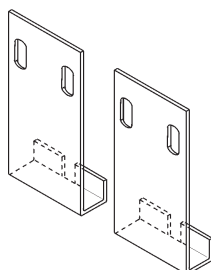

Two stacking brackets (shown at left) are included in the parts bag shipped with each incubator.

Figure 1-3. Stacking Brackets

1. Remove the cover plate securing the door cord from the incubator to be on top. See Figure 1-4. Disconnect the plug from the connector.
2. Remove the four screws securing the door hinges to the unit. Remove the door and set it aside.

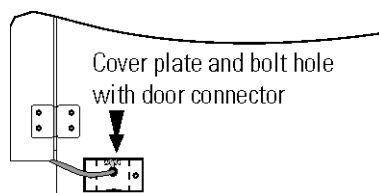

Figure 1-4. Cover Plate

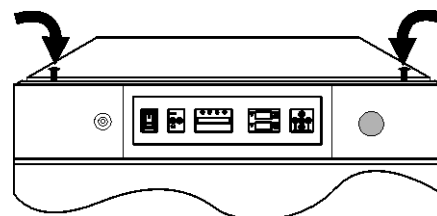

Figure 1-5. Hole Plug Locations

3. Unscrew the two hole plugs from the top cover of the incubator to be the bottom of the stack (Figure 1-5).
4. Unscrew and remove the 4 leveling feet from the unit to be stacked on top and lift it onto the bottom unit. Align all sides.

Warning This incubator weighs 260 lbs. Have sufficient personnel available when lifting. Lift the unit by the sides of the cabinet base to avoid placing stress on the outer door hinge. ▲

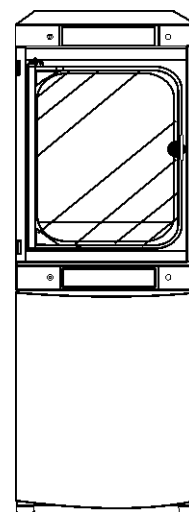

Figure 1-6. Bolt Holes

5. Insert the stacking brackets into the slots at the back of the stacked units as shown in Figure 1-7.
6. Align the slotted holes in the brackets with the mounting holes on the back of the top incubator. Secure the brackets with the screws and washers provided in the parts bag. See Figure 1-8.

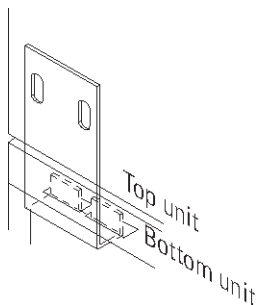

Figure 1-7. Bracket into Slot

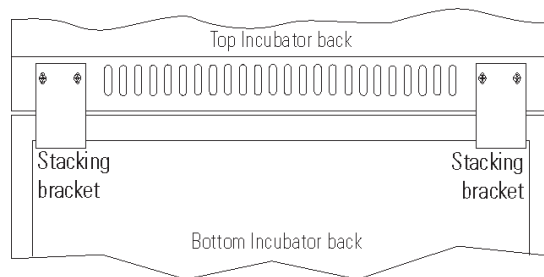

Figure 1-8. Installed Brackets on Back of Unit

7. Thread one 1/4 x 20 bolt and washer included with the stacking brackets, into the hole behind the cover plate. Do not tighten. Refer to Figure 1-9.
8. Remove the cover plate from the same area on the other side of the top unit.

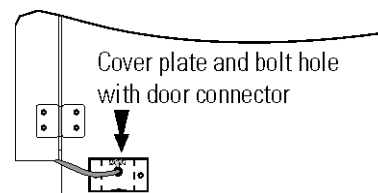

Figure 1-9. Bolt Hole

9. Thread the other 1/4 x 20 bolt and washer into this hole.
10. Tighten the bolts on both sides.
11. Assemble the door hinges to the unit. Secure with the screws.
12. Plug the door cord into the connector, as previously. Secure the cover plate.
13. Install the cover plate on the other side of the unit.
14. The stacked incubators are ready for service.

Preliminary Cleaning

1. Using a suitable laboratory disinfectant, clean all interior surfaces.

Shelf Installation

1. Install the large sheet metal side ducts with the tabs facing into the center of the chamber with their slots up. There are no right side or left side ducts, simply rotate one of them to fit the opposite side. Tilt the side ducts as they are placed into the chamber so the tops fit into the top air duct, then guide them into the vertical position. Figure 1-10 shows the side duct as it would be oriented for the right side of the chamber.

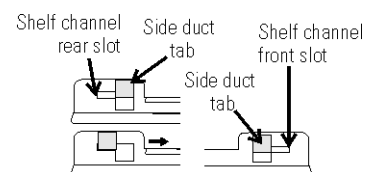
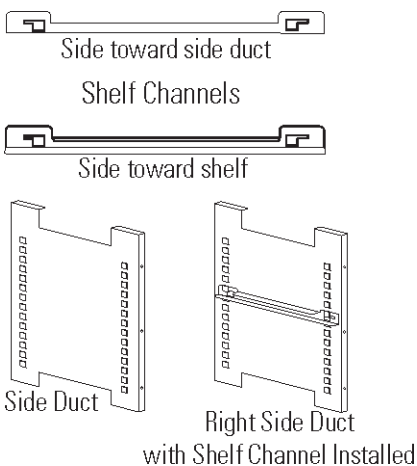

Figure 1-10. Shelf Channels and Side Ducts **Figure 1-11.** Channels and Slots

2. Referring to Figure 1-10, note that there is no difference in the left and right shelf channels.
3. Install the shelf channels by placing the channel's rear slot over the appropriate rear tab on the side duct. Pull the shelf channel forward and engage the channel's front slot into the side duct's appropriate forward tab. Refer to Figure 1-11.
4. Figure 1-10 shows one of the channels installed on the right side duct.

Access Port Filter & CO₂ Sensor Cover Plate

1. Locate the opening in the top left corner of the interior chamber. Remove the tape from the opening on the outside of the unit.
2. Locate the stopper with filter in the hardware bag. Lift the metal port cover and install the assembly in the opening inside the chamber. See Figure 1-12.
3. Also in the hardware bag is the CO₂ sensor cover plate. Install, using the 1/4-turn fasteners. Refer to Figure 1-12 for the location.

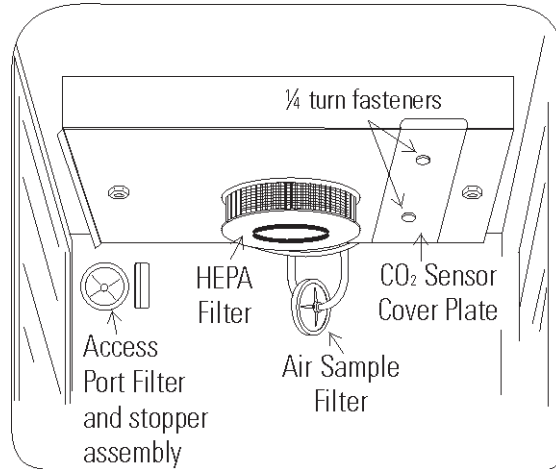

Figure 1-12. Filter and Plate

Air Sample Filter Installation

1. Remove the filter from the shipping bag.
2. Install the air sample filter assembly to the black hose barb behind the top duct.
3. Insert the other end of the filter assembly onto the metal tubing on the top duct. Refer to the Figure 1-13.

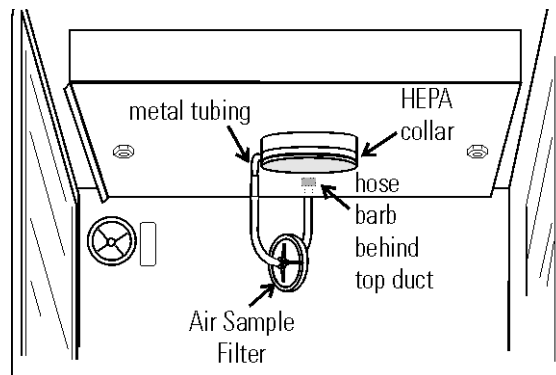

Figure 1-13. Air Sample Filter Installation

HEPA Filter Installation

Caution Be careful when the filter. The media can be damaged if it is mishandled. To avoid damage to the incubator, do not operate the unit without the HEPA filter in place. ▲

1. Remove the filter from the shipping box.
2. Remove the plastic coating from the filter, using caution not to touch the filter media.
3. Install the filter as shown in Figure 1-13. Refer to Section 5 for HEPA filter maintenance.

Caution The media of the filter can be damaged if mishandled. To avoid damage to the incubator, do not operate the unit without the HEPA filter in place. ▲

Leveling the Unit

Check the unit for being level by placing a bubble-style level on one of the shelves. Turn the hex nut on the leveler counterclockwise to lengthen the leg or clockwise to shorten it. Level the unit front-to-back and left-to-right.

Electrical Power Connection

See the serial tag on the side of the unit for electrical specifications or refer to the electrical schematics at the end of this manual.

Caution Serial tag rating is based on amperage draw during sterilization cycle. Normal operating amperage is much less. Ensure that electrical circuit will handle amp draw of sterilization cycle. Connect the incubator to a grounded, dedicated circuit. The power cord connector is the mains disconnect device for the incubator. Position the unit so that it can be easily disconnected. ▲

Plug the provided power cord into the power inlet connector on the back of the cabinet (Figure 1-14), then into the grounded, dedicated, electrical circuit.

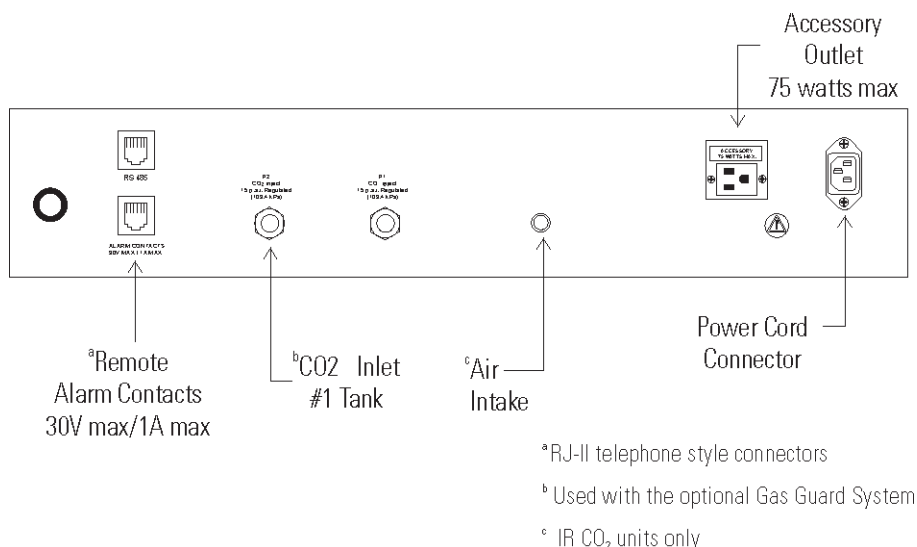

Figure 1-14. Back of Cabinet

Filling the Humidity Pan

Fill the humidity pan with sterile distilled water to within 1/2" of the top. Place the pan directly in the center of the incubator floor.

For applications requiring high humidity, the pan should be placed against the left side wall of the incubator. The side ducts have been modified to allow the pan to be placed against the wall. Optimum humidity is achieved by capping the CO₂ sample port. This will, however, cause condensation in the chamber. To enhance RH recovery from door openings, place a second humidity pan in the right side duct.

For best operation of the incubator, sterilized distilled, demineralized or de-ionized water should be used in the humidity pan. Refer to ASTM Standard D5391-93 or D4195-88 for measuring water purity.

Distillation systems and reverse osmosis water purity systems produce water that is neutral in pH (approximately 7) and is the preferred water to use for humidification. High purity, ultra pure or milli-q water is considered an aggressive solvent and slightly acidic. While it may be used, it is not preferred. Chlorinated tap water, or additives containing chlorine, is not to be used as chlorine can deteriorate the stainless steel. Tap water may also have a high mineral content, which would produce a build-up of scale in the reservoir.

Even high purity water can contain bacteria and organic contaminants.

Water should always be sterilized or treated with a decontaminant, safe for use with stainless steel as well as safe for the product, prior to being introduced into the humidity pan.

Check the level and change the water frequently to avoid contamination. Do not allow the water level to fluctuate significantly. “Dry-outs” will have an adverse effect on the humidity level and CO₂ calibration of the T/C units.

Caution Use of chlorinated water, or decontamination products containing chlorine, will deteriorate the stainless steel and cause rust, voiding the warranty. ▲

Connecting the CO₂ Gas Supply

Warning High concentrations of CO₂ gas can cause asphyxiation! OSHA Standards specify that employee exposure to carbon dioxide in any eight-hour shift of a 40-hour work week shall not exceed the eight-hour time weighted average of 5000 PPM (0.5% CO₂). The short term exposure limit for 15 minutes or less is 30,000 ppm (3% CO₂). Carbon dioxide monitors are recommended for confined areas where concentrations of carbon dioxide gas can accumulate. ▲

Warning This incubator is designed to be operated with CO₂ gas only. Connecting a flammable or toxic gas can result in a hazardous condition. Gases other than CO₂ should not be connected to this equipment. CO₂ gas cylinders have a UN1013 label on the cylinder and are equipped with a CGA 320 outlet valve. Check the gas cylinder for the proper identification labels. The CO₂ gas supply being connected to the incubator should be industrial grade, 99.5% pure. Do not use CO₂ gas cylinders equipped with siphon tubes. A siphon tube is used to extract liquid CO₂ from the cylinder which can damage the pressure regulator. Consult with your gas supplier to ensure that the CO₂ cylinder does not contain a siphon tube. Gas cylinders should also be secured to a wall or other stationary object to prevent them from tipping.

A two-stage CO₂ pressure regulator is required to be installed on the outlet valve of the gas cylinder. Input pressure to the incubator must be maintained at 15 psig (103.4 kPa) for proper performance of the CO₂ control system. A single stage CO₂ pressure regulator will not maintain 15 psig (103.4 kPa) to the incubator as the pressure in the CO₂ cylinder decreases; therefore, a two stage regulator is recommended.

Connecting CO₂ Gas Supply (continued)

Warning If higher purity CO₂ is desired inside the incubator (greater than 99.5% pure), the pressure regulator should be constructed with a stainless steel diaphragm, along with specifying the purity of the CO₂ from the gas supplier. Follow the manufacturer's instructions to ensure proper and safe installation of the pressure regulator on the gas cylinder.

Consult your facility safety officer to ensure that the equipment is installed in accordance with the codes and regulations that are applicable in your area. ▲

The CO₂ gas supply being connected should be industrial grade 99.5% pure and should not contain siphon tubes. Install a two-stage pressure regulator at the cylinder outlet. The high pressure gauge at the tank should have 0-2000 psig range. The low pressure gauge, at the incubator inlet, should have a 0-30 psig range. Input pressure to the incubator must be maintained at 15 psig (103.4 kPa).

The incubator has serrated fittings on the back of the cabinet to connect the gas supply. Refer to Figure 1-14. The fitting is labeled CO₂ Inlet #1 Tank. Make sure that the connections are secured with clamps. Check all fittings for leaks.

For units having the CO₂ Gas Guard option, refer to Section 6.

Incubator Start-Up

With the incubator properly installed and connected to power, the humidity pan filled, and the unit connected to gas supplies, system setpoints can be entered. The following setpoints can be entered in SET mode: Temperature, Overtemperature and CO₂. To enter SET mode, press the MODE key until the SET indicator lights. Press the right and/or left arrow keys until the proper parameter appears in the message display. See Chart 1-1 for more detail.

Setting the Operating Temperature

All 8000DH Series incubators have an operating temperature range of 10°C to 50°C, depending on ambient temperature. The incubator is shipped from the factory with a temperature setpoint of 10°C. At this setting, all heaters are turned off.

Setting the Operating Temperature (continued)

To change the operating temperature setpoint:

1. Press the MODE key until the SET indicator lights.
2. Press the right arrow until “Temp XX.X” is displayed in the message display.
3. Press the up/down arrow key until the desired temperature setpoint is displayed.
4. Press ENTER to save the setpoint.
5. Press the MODE key until the RUN indicator lights for RUN mode or press the right/left arrow keys to go to next/previous parameter.

Setting the Overtemp Setpoint

Caution The independent overtemp system is designed as a safety to protect the incubator only. It is not intended to protect or limit the maximum temperature of the cell cultures or customer’s equipment inside the incubator if an overtemp condition occurs. ▲

8000DH Series incubators are equipped with a secondary temperature monitoring system to monitor the air temperature inside the cabinet. This system is designed as a safety device to turn off all heaters in the event of a temperature control failure. Temperature control in the incubator will be $\pm 1^\circ$ of the overtemp setpoint.

The overtemperature is set by the factory (default) at 40°C. However, the overtemp can be set up to 55°C in 0.5° increments.

If the incubator’s operating temperature setpoint is set above the overtemp setpoint, the overtemp setpoint will automatically update to 1°C above the temperature setpoint. It is recommended that the overtemp setpoint be maintained at 1°C over the operating temperature setpoint.

Setting the Overtemp Setpoint (continued)

To set the Overtemp setpoint:

1. Press the MODE key until the SET indicator lights
2. Press the right arrow until Otemp XX.X is displayed in the message display
3. Press the up or down arrow key until the desired Overtemp setpoint is displayed
4. Press ENTER to save the setting
5. Press the MODE key until the RUN indicator lights or press the right or left arrow to go to the next or previous parameter.

Setting the CO₂ Setpoint

All T/C CO₂ cells are calibrated at the factory at 37°C, high humidity, and 10% CO₂. Therefore, if a temperature setpoint of 37°C has been entered, the humidity pan has been filled and the CO₂ control is to run between 0-10% with a T/C CO₂ sensor, the CO₂ setpoint may be entered immediately. Otherwise, it is important to allow the unit 12 hours to stabilize at the temperature setpoint before entering the CO₂ setpoint.

Both models of the incubator have a CO₂ setpoint range of 0.0% to 20.0%. The incubator is shipped from the factory with a CO₂ setpoint of 0.0%. At this setting, all CO₂ control and alarms are turned off. To change the CO₂ setpoint:

1. Press the MODE key until the SET indicator lights.
2. Press the right arrow until "CO₂ XX.X" is displayed in the message display.
3. Press the up/down arrows until the desired CO₂ setpoint is displayed.
4. Press ENTER to save the setpoint.
5. Press the MODE key until the RUN indicator lights to go to RUN mode or press the right/left arrow keys to go to next/previous parameter.

Chart 1-1. Set Mode

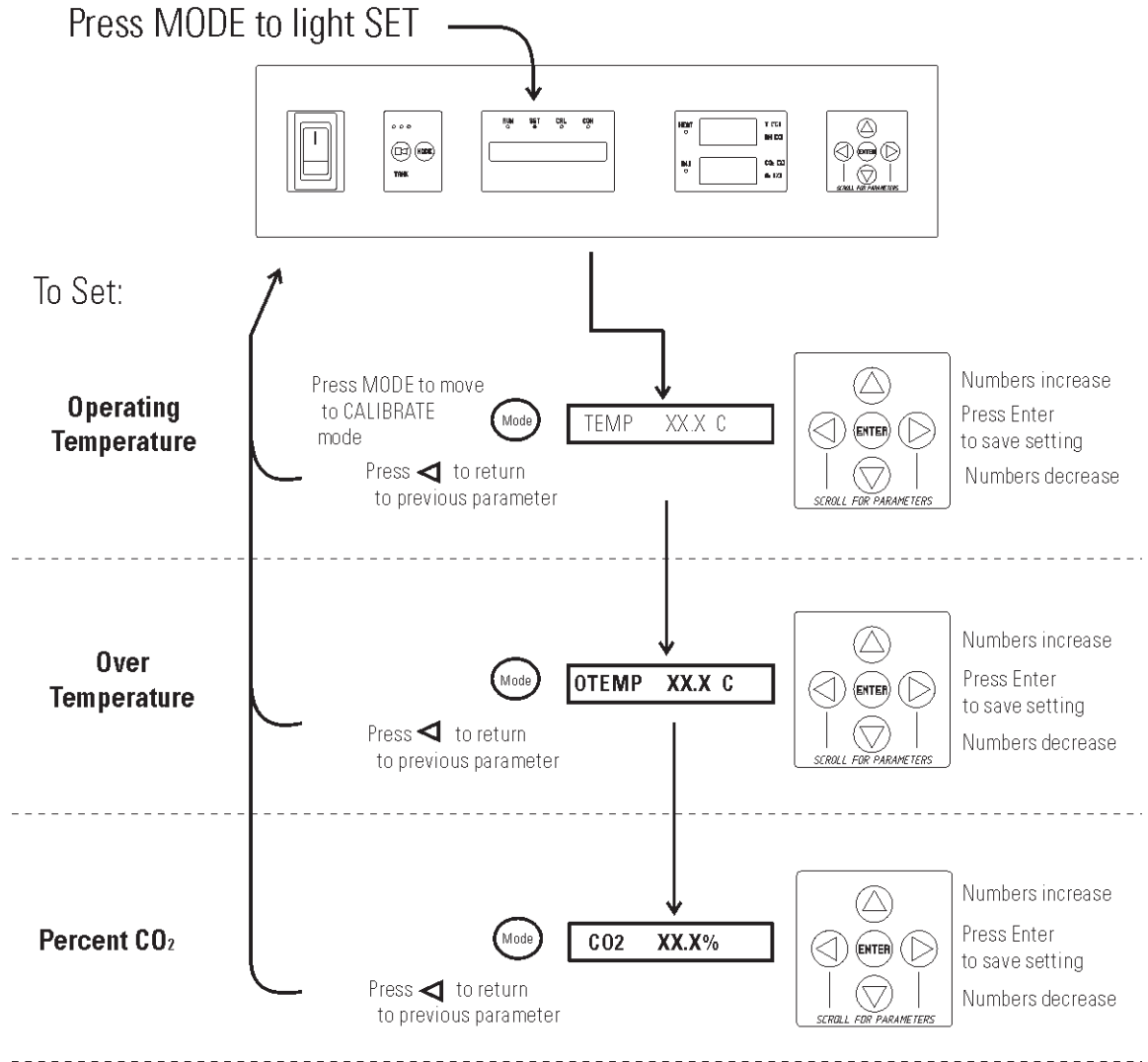

Section 2 Calibration

After the unit has stabilized, several different systems can be calibrated. In Calibration mode, the air temperature, CO₂ and RH levels can be calibrated to reference instruments. To access Calibration mode, press the MODE key until the CAL indicator lights. Press the right and/or left arrow until the appropriate parameter appears in the message display. See Chart 2-1 at the end of this section for more detail.

Calibration frequency is dependent on use, ambient conditions and accuracy required. A good laboratory practice would require at least an annual calibration check. On new installations, all parameters should be checked after the stabilization period.

Prior to calibration, the user should be aware of the following system functions. While the unit is in Calibration mode, all system control functions are stopped so the unit remains stable. Readout of the system being calibrated appears on the message display. If no keys are pressed for approximately five minutes while in Calibration mode, the system resets to RUN mode so control functions are reactivated.

Caution Before making any calibration or adjustments to the unit, it is imperative that all reference instruments be properly calibrated. ▲

Temperature

Before calibration, allow the cabinet temperature to stabilize. Place the calibrated instrument in the center of the chamber. The instrument should be in the airflow, not against the shelf.

Temperature Stabilization Periods

Startup - Allow 12 hours for the temperature in the cabinet to stabilize before proceeding.

Already Operating - Allow at least 2 hours after the display reaches setpoint for temperature to stabilize before proceeding.

Temperature (continued)

1. Press the MODE key until CAL indicator lights.
2. Press the right arrow until “TEMPCAL XX.X” appears in the message display.
3. Press up/down arrow to match display to calibrated instrument.
4. Press ENTER to store calibration.
5. Press the MODE key to return to RUN or the right/left arrow to go to next/previous parameter.

Thermal Conductivity CO₂ System

Models 3598 and 3584 have a thermal conductivity (T/C) CO₂ sensor. Thermal conductivity of the incubator atmosphere is not only effected by the quantity of CO₂ present but also by the air temperature and water vapor present in the incubator atmosphere. In monitoring the effects of CO₂, air temperature and absolute humidity must be held constant so any change in thermal conductivity is caused by a change in CO₂ concentration.

Changing temperature or changing from elevated humidity to room ambient humidity levels will necessitate a re-calibration of the CO₂ control.

T/C CO₂ Sensor Stabilization Periods

Some T/C CO₂ sensors go through an aging period, especially on new installations. Calibration should be checked on a weekly basis and adjusted as necessary. When stabilization occurs, checks may become less frequent.

Start -Up - The CO₂ sensor has been calibrated at the factory for 37°C and elevated humidity. Allow the temperature, humidity, and CO₂ levels in the chamber to stabilize at least 12 hours before checking the CO₂ concentration with an independent instrument.

Presently Operating - Make sure the chamber doors are closed. Allow at least 2 hours after the temperature and CO₂ displays reach their setpoints for chamber atmosphere stabilization.

Thermal Conductivity CO₂ System (continued)

1. Make sure the stabilization periods outlined above are followed.
2. Sample the chamber atmosphere through the sample port with an independent instrument. Sample the atmosphere at least 3 times to ensure accuracy of the instrument.
3. Press the MODE key until the CAL indicator lights.
4. Press the right arrow until “CO₂ CAL XX.X” is displayed in the message display.
5. Press the up /down arrows to change the display to match the independent instrument.
6. Press ENTER to store the calibration.
7. Press the MODE key to return to RUN or the right or left arrows to go to the next/ previous parameter.

Infrared CO₂ System

Models 3599 and 3585 have an infrared (IR) CO₂ sensor. Infrared CO₂ sensors are not effected by chamber atmosphere temperature or humidity. However, the light detector in the sensor is effected by wide temperature changes. Therefore, changing temperature setpoints could necessitate a recalibration of the CO₂. Chamber temperature should be allowed to stabilize before checking CO₂ concentrations with an independent instrument, especially on start-up.

IR CO₂ Sensor Stabilization Times

Start-Up- Allow the temperature and the CO₂ of the cabinet to stabilize at least 12 hours before proceeding.

Presently Operating - Allow CO₂ to stabilize at least 2 hours at setpoint before proceeding.

Infrared CO₂ System (continued)

1. Measure the CO₂ concentration in the chamber through the gas sample port with a Fyrite or other independent instrument. Several readings should be taken to ensure accuracy.
2. Press the MODE key until the CAL indicator lights.
3. Press the right arrow until “IR CAL XX.X” appears in the message display.
4. Press the up/down arrow to adjust the display to match the independent instrument reading.
5. Press ENTER to store the calibration.
6. Press the MODE key to return to RUN mode.

Relative Humidity

Model 3584 and 3585 incubators are equipped with an optional direct-readout relative humidity sensor. This is a readout only of the chamber relative humidity level. It does not provide any control of the relative humidity in the cabinet.

Relative Humidity Stabilization Times

Start-Up - Allow 12 hours for the relative humidity and temperature in the chamber to stabilize before proceeding.

Already Operating - Allow at least 2 hours after temperature display reaches setpoint for relative humidity to stabilize before proceeding.

1. Place an accurate independent instrument in the center of the chamber. Allow at least 30 minutes for RH to stabilize.
2. Press the MODE key until the CAL indicator lights.
3. Press the right arrow key until “RH CAL XX” appears in the message display.
4. Press the up/down arrow to match the display to the independent instrument.
5. Press ENTER to store the calibration.
6. Press the MODE key to return to RUN mode.

Relative Humidity (continued)

If a reliable RH measuring device is not available, the display can be calibrated to a typical level;

1. Follow the RH stabilization periods outlined above.
2. With a full humidity pan and stable temperature, the relative humidity in the chamber will be 95%.
3. Using Step 3-5 of the relative humidity sensor adjustment, adjust the display to 95%.

This calibration method should be accurate to within 5%.

Chart 2-1. Calibration Mode

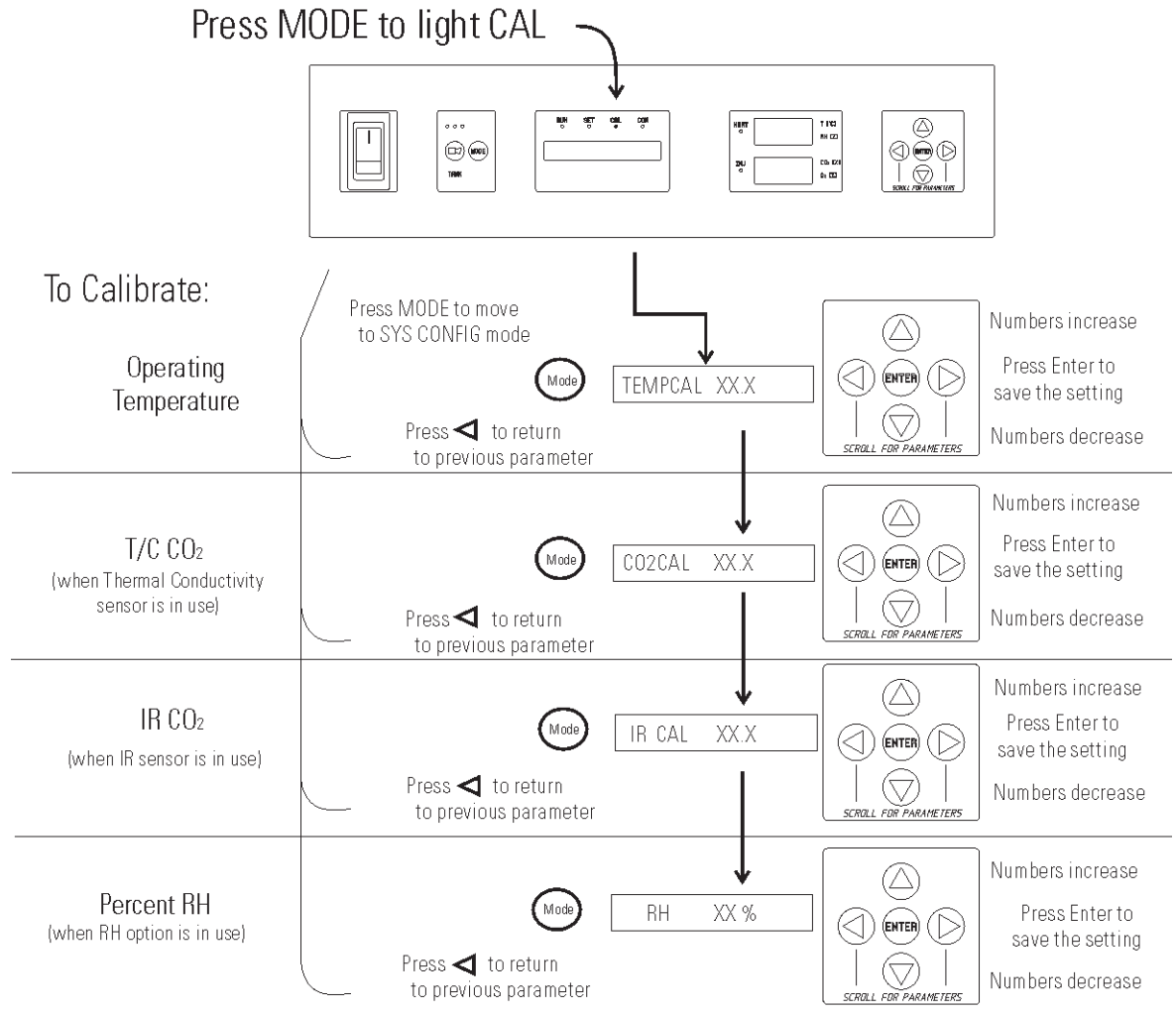

Section 3 Configuration

Several features available in Configuration mode allow custom setup of the incubator. These features are listed with descriptions below. All features may not be necessary in all applications, but are available if needed. To enter Configuration mode, press the MODE key until the CON indicator lights. Press the right and/or left arrow until the appropriate parameter appears in the message display. See Chart 3-1 for more detail.

Turn Audible Alarm ON/OFF

The audible alarm can be turned on or off. The factory setting is ON.

1. Press the MODE key until the CON indicator lights.
2. Press the right arrow until AUDIBLE XXX shows in the message display.
3. Press the up/down arrow to toggle AUDIBLE ON/OFF.
4. Press ENTER to save the setting.
5. Press the MODE key to return to RUN mode or right/left arrow to go to next/previous parameter.

New HEPA Filter

When the REPLACE HEPA reminder displays and the visual alarm flashes, the specified time has elapsed and the HEPA filter should be replaced. To clear the display and reset the timer after replacing the HEPA filter with a new one, follow the steps below.

1. Press the MODE key until the CON indicator lights.
2. Press the right arrow until NEW HEPA shows in the message display.
3. Press ENTER to restart the timer and clear the REPLACE HEPA alarm.
4. Press the MODE key to return to RUN mode.

Set REPLACE HEPA filter reminder

A HEPA filter replacement timer can be set for a specific amount of time, from 1 to 12 months of actual unit running time. Time will not accrue when the unit is turned off. The default time is 6 months. When the allotted time runs out, REPLACE HEPA appears in the display and the visual alarm flashes. To set the reminder, use the following procedure.

1. Press the MODE key until the CON indicator lights.
2. Press the right arrow until REPL HEPA XX is displayed.
3. Press the up/down arrow to choose the number of months desired.
4. Press ENTER to save the number.
5. Press the MODE key to return to RUN mode or right/left arrow to go to next/previous parameter.

Note After the reminder has been set, check the allotted time remaining by going to Configuration mode, then pressing the right arrow until NEW HEPA XXX displays. This number is the remaining days before the filter replacement time specified runs out. For example, if 12 months was chosen in the REPL HEPA XX message display, the NEW HEPA number would be 365 days. ▲

Set Access Code

A 3-digit Access Code can be entered to avoid unauthorized personnel from changing the setpoints, calibration, or configuration. A setting of 000 bypasses the access code. The factory setting is 000.

1. Press the MODE key until the CON indicator lights.
2. Press the right arrow until ACC CODE XXX shows in the message display.
3. Press up/down arrow to change the access code.
4. Press ENTER to save the access code.
5. Press the MODE key to return to the RUN mode or right/left arrow to go to next/previous parameter.

Set Low Temp Alarm Limit (tracking alarm)

The low temp alarm limit is the deviation from the temperature setpoint which causes a low temp alarm. The low temp alarm is variable from 0.5° below setpoint to 5° below setpoint. The factory setting is 1° below setpoint. A minus sign (-) in the display indicates that the alarm setting is below the setpoint.

1. Press the MODE key until the CON indicator lights.
2. Press the right arrow until TEMP LO -X.X shows in the message display.
3. Press up/down arrow to change the low temp alarm limit.
4. Press ENTER to save the low temp alarm limit.
5. Press the MODE key to return to RUN mode or right/left arrow to go to next/previous parameter.

Enable Low Temp Alarm to Trip Contacts

The low temperature alarm can be programmed to trip the remote alarm contacts. A setting of ON allows this, an OFF setting blocks the low temp alarm from tripping the contacts. The factory setting is ON.

1. Press the MODE key until the CON indicator lights.
2. Press the right arrow until TMP RLY XXX displays.
3. Press the up/down key to toggle the setting ON/OFF.
4. Press ENTER to save the setting
5. Press the MODE key to return to RUN mode, or the right/left arrow to go to next/previous parameter.

Set Low CO₂ Alarm Limit (tracking alarm)

The low CO₂ alarm limit is the deviation from the CO₂ setpoint which will cause a low CO₂ alarm. The setpoint is variable from 0.5% CO₂ below setpoint to 5.0% CO₂ below setpoint. The factory setting is 1.0% CO₂ below setpoint. A minus sign (-) in the display indicates that the alarm setting is below the setpoint.

1. Press the MODE key until the CON indicator lights.
2. Press the right arrow until CO2 LO -X.X shows in the message display.
3. Press up/down arrow to change the low CO₂ alarm limit.
4. Press ENTER to save the low CO₂ alarm limit.
5. Press the MODE key to return to RUN mode or right/left arrow to go to next/previous parameter.

Set High CO₂ Alarm Limit (tracking alarm)

The high CO₂ alarm limit is the deviation from the CO₂ setpoint which will cause a high CO₂ alarm. The setpoint is variable from 0.5% CO₂ above setpoint to 5.0% CO₂ above setpoint. The factory setting is 1.0% CO₂ above setpoint.

1. Press the MODE key until the CON indicator lights.
2. Press the right arrow until CO2 HI X.X shows in the message display.
3. Press up/down arrow to change the high CO₂ alarm limit.
4. Press ENTER to save the high CO₂ alarm limit.
5. Press the MODE key to return to RUN mode, or right/left arrow to go to next/previous parameter.

Enable CO₂ Alarms to Trip Contacts

High and Low CO₂ alarms can be programmed to trip the remote alarm contacts. A setting of ON allows this, a setting of OFF blocks CO₂ alarms from tripping the contacts. The factory setting is ON.

1. Press the MODE key until the CON indicator lights.
2. Press the right arrow until CO₂ RLY XXX shows in the message display.
3. Press up/down arrow to toggle the setting ON/OFF.
4. Press ENTER to save the setting.
5. Press the MODE key to return to RUN mode or right/left arrow to go to next/previous parameter.

Set New Zero Number for T/C CO₂ Sensors

If a new T/C CO₂ sensor is being installed, the two numbers on the factory installed sticker on the T/C cell must be entered to calibrate CO₂ in the unit.

Note For the technician's convenience, a label containing the two numbers on the T/C cell is affixed inside the electronics drawer. ▲

1. Press the MODE key until the CON indicator lights.
2. Press the right arrow until T/CZ# XXXX shows in the message display.
3. Press up/down arrow to change the zero number to match the sticker.
4. Press ENTER to save the setting.
5. Press the MODE key to return to RUN mode or right/left arrow to go to next/previous parameter.

Set New Span Number for T/C CO₂ Sensors

If a new T/C CO₂ sensor is being installed, the two numbers on the factory installed sticker on the T/C cell must be entered to calibrate the CO₂ in the unit.

Note For the technician's convenience, a label containing the two numbers on the T/C cell is affixed inside the electronics drawer. ▲

1. Press the MODE key until the CON indicator lights.
2. Press the right arrow until T/CS# XXXX shows in the message display.
3. Press up/down arrow to change the span number to match the sticker.
4. Press ENTER to save the setting.
5. Press the MODE key to return to RUN mode or right/left arrow to go to next/previous parameter.

Setting a Low RH Alarm Limit

On units with the RH option installed, a low RH alarm limit may be entered. The low RH alarm limit is the %RH in the cabinet that causes a low RH alarm. The setpoint is variable from setpoint 0 to 90% RH. The factory setting is 0% RH, which disables the alarm.

1. Press the MODE key until the CON indicator lights.
2. Press the right arrow until RH LO XX shows in the message display.
3. Press up/down arrow to change the RH low alarm limit.
4. Press ENTER to save the RH low alarm limit.
5. Press the MODE key to return to RUN mode or right/left arrow to go to next/previous parameter.

Enable RH Alarms to Trip Contacts

The low RH alarm can be programmed to trip the remote alarm contacts. A setting of ON allows this, a setting of OFF blocks the RH alarm from tripping the contacts. The factory setting is ON.

1. Press the MODE key until the CON indicator lights.
2. Press the right arrow until RH RLY XXX shows in the message display.
3. Press up/down arrow to toggle the setting ON/OFF.
4. Press ENTER to save the setting.
5. Press the MODE key to return to RUN mode or right/left arrow to go to next/previous parameter.

Enabling Temp/RH to be Displayed

On units equipped with the RH option, the upper seven segment display on the control panel can be configured to display Temp continuously, RH continuously, or toggle between Temp and RH. If the units does not have RH, the upper display always shows temperature. If temperature is set to ON, and the RH is set OFF, temperature shows continuously. If temperature is set to OFF and RH is set to ON, RH shows continuously. If both are turned ON, the display toggles between the two. The factory setting defaults to toggle mode if the RH option is present.

1. Press the MODE key until the CON indicator lights.
2. Press the right arrow until DISP TMP XXX or DISP RH XXX shows in the message display.
3. Press up/down arrow to toggle the setting ON/OFF.
4. Press ENTER to save the setting.
5. Press the MODE key to return to RUN mode or right/left arrow to go to next/previous parameter.

Chart 3-1. Configuration Mode Page 1 of 3

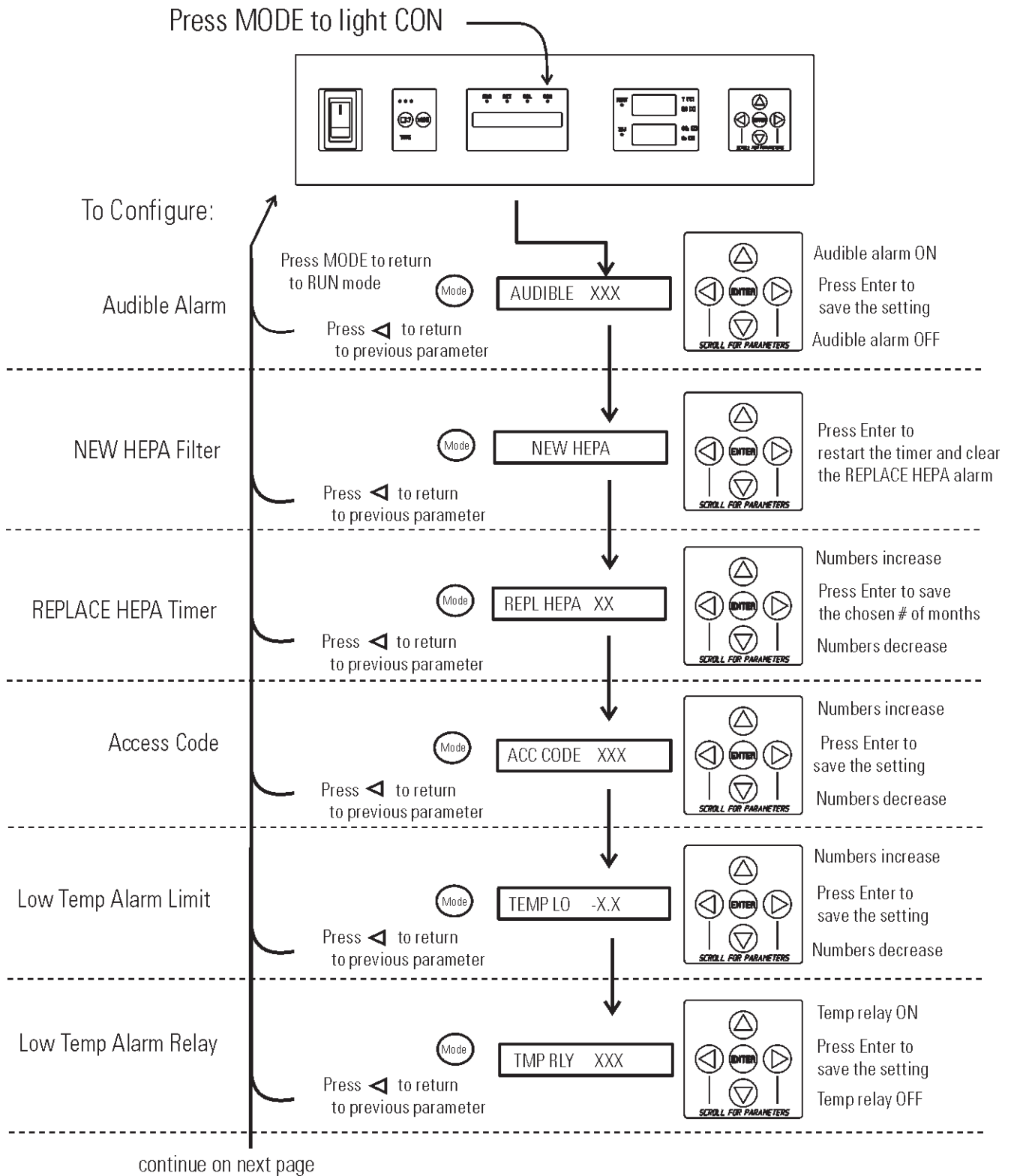

Chart 3-1. Configuration Mode Page 2 of 3

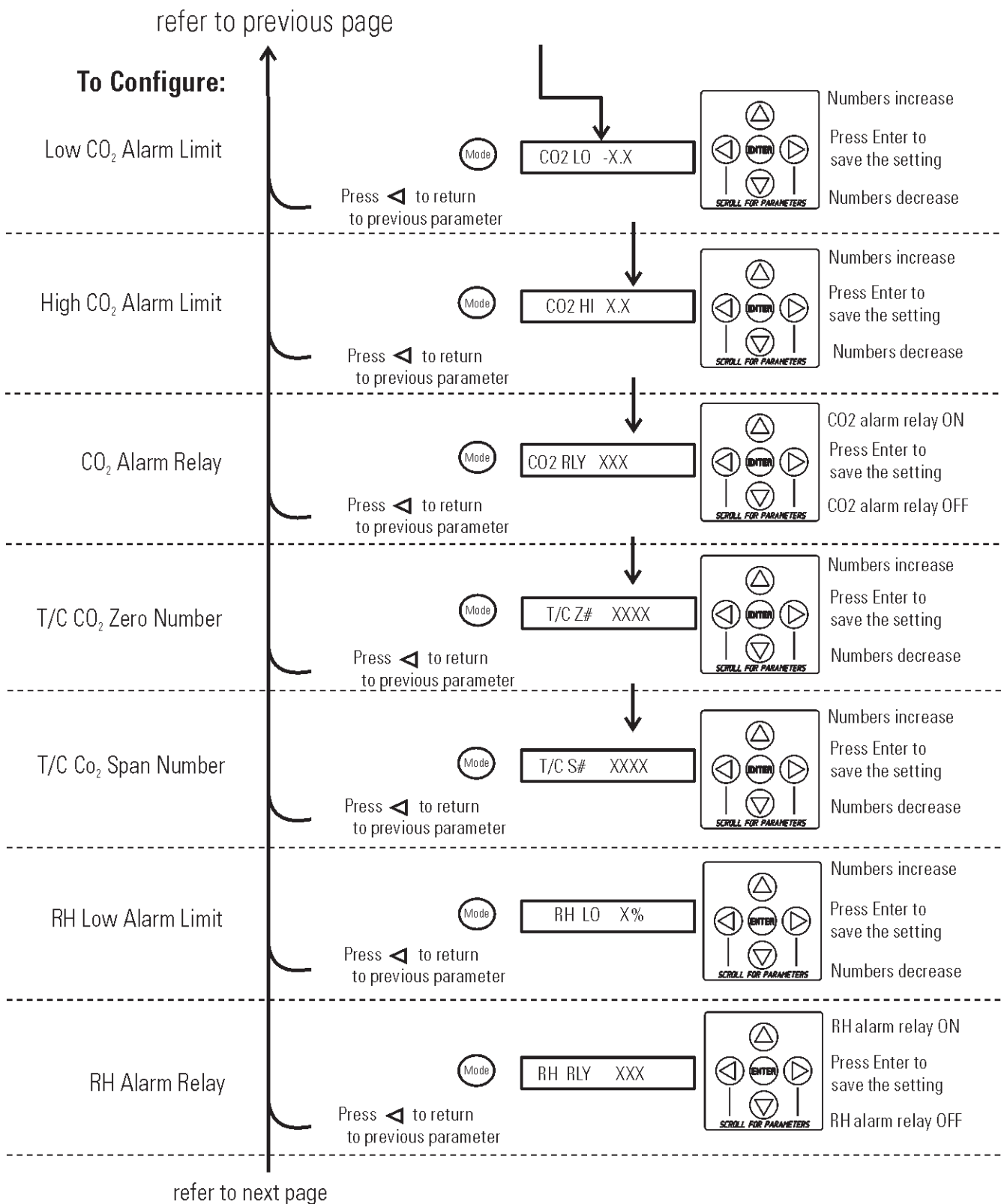
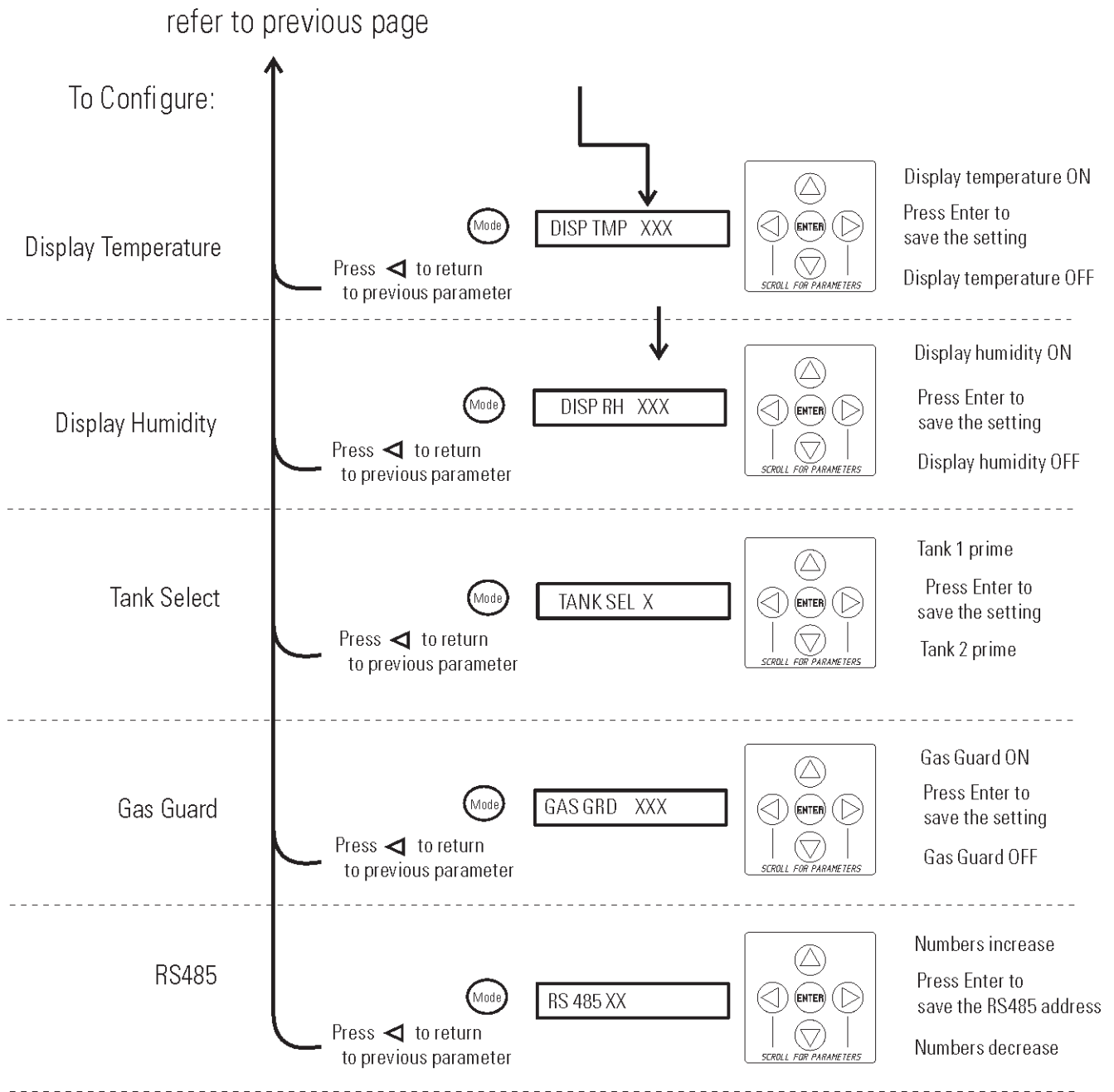

Chart 3-1. Configuration Page 3 of 3



Section 4 Alarms



The 8000DH Series incubator alarm system is shown in the table below. When an alarm is active, the message appears in the LED message display. Pressing  disables the audible alarm for the ringback period. However, the visual alarm continues until the incubator returns to a normal condition. The alarms are momentary alarms only. When an alarm condition occurs and then returns to normal, the incubator automatically clears the alarm condition and the message display.

Table 4-1. Alarm and Description

Description	Message	Delay	Ringback	Relay
No alarm condition exists	SYSTEM OK or CLASS 100	-----	-----	-----
Temp > Otemp Set point	SYS IN OTEMP	0 min.	15 min.	Yes
Air Temp Sensor Fault (See Section 4)	AIR SNSR ERR	0 min.	15 min.	No
Temperature Controller Failure (See Sect. 4)	TMP CTRL ERR	0 min.	15 min.	YES
CO2 Sensor Fault (See Section 4)	CO2 SNSR ERR	0 min.	15 min.	No
Replace HEPA filter reminder-set time expired (See Section 3)	REPLACE HEPA	0 min.	-----	No
Inner Door is Open	DOOR OPEN	15 min.	15 min.	No
CO2 is higher than CO2 High Tracking Alarm	CO2 IS HIGH	15 min.	15 min.	Programmable
CO2 is lower than CO2 Low Tracking Alarm	CO2 IS LOW	15 min.	15 min.	Programmable
TEMP is lower TEMP Low Tracking Alarm	TEMP IS LOW	15 min.	15 min.	Programmable
RH is lower than RH Low Limit Alarm (RH option)	RH IS LOW	30 min.	30 min.	Programmable

- All alarm delays and ringback times are ±30 seconds -

When multiple alarm conditions occur, active messages are shown in the message display one at a time, updating at 5 second intervals. Pressing  during multiple alarms causes all active alarms to be silenced and to ring back in 15 minutes.

The TEMP IS LOW alarm is disabled when the Temp set point is 10°C. The CO₂ alarms are disabled when the CO₂ set point is 0.0%.

Temp Controller Failure TMP CNTR ERR

In addition to other safety features designed into 8000DH Series incubators, a thermostat is provided to monitor the cabinet's temperature. In the unlikely event of a temperature control failure, the thermostat will turn off all heaters at a cabinet temperature of 160°C, $\pm 5\%$. This is intended to be a safety feature to protect the incubator, and is not intended to protect the cell cultures or the equipment inside the chamber should a temperature control failure occur. Should such a failure occur, contact the Technical Services Department or your local distributor.

Sensor Fault Alarms

The microprocessor in 8000DH Series incubators continually scans all available sensors to ensure that they are operating properly. Should an error be detected, the incubator sounds an alarm and shows the appropriate message. Contact the Technical Services Department (1-888-213-1790) or your local distributor.



PREVENTIVE MAINTENANCE

Incubators

Your Thermo equipment has been thoroughly tested and calibrated before shipment. Regular preventive maintenance is important to keep your unit functioning properly. The operator should perform routine cleaning and maintenance on a regular basis. For maximum performance and efficiency, it is recommended the unit be checked and calibrated periodically by a qualified service technician.

The following is a condensed list of preventive maintenance requirements. See the specified section of the instruction manual for further details.

Thermo has qualified service technicians, using NIST traceable instruments, available in many areas. For more information on Preventive Maintenance or Extended Warranties, please contact us at the number listed below.

Cleaning and calibration adjustment intervals are dependent upon use, environmental conditions and accuracy required.

Tips for all incubators:

- Do NOT use bleach or any disinfectant that has high chloros
- Use sterile, distilled or demineralized water.
- Avoid spraying cleaner on the CO₂ sensor.
- Do not use powdered gloves for tissue cultures.

Millcreek Road, Box 649 • Marietta, Ohio 45750 USA • 740-373-4763
 USA and Canada 888-213-1790 • Telefax: 740-373-4189 • <http://www.services.controlenv@thermo.com>

Forma® Incubators _____ Preventive Maintenance

Preventive Maintenance for Series 8000DH Incubators

Refer to Manual Section	Action	Daily	Weekly	Monthly	3 to 6 Months	Yearly
--	Check CO ₂ tank levels.	✓				
--	Inspect door latch, hinges and door gasket seal.					✓
1	Check water level in the humidity pan, ½" from top.		✓			
2	* Verify and document CO ₂ , humidity and temperature calibration, as applicable (See Calibration).					✓
	Disinfect the interior of the incubator (See Routine Maintenance).				✓	
1	Replace HEPA, access port filter, air sample filter, and CO ₂ filters*, if applicable (or as needed).					✓
5	Perform sterilization cycle as needed.					

* Qualified service technicians only

Section 5 Routine Maintenance

Warning If the unit has been in service, turn it off and disconnect the power cord connector before proceeding with any maintenance. ▲

Caution Before using any cleaning method except those recommended by the manufacturer, users must check with the manufacturer that the proposed method will not damage the equipment. ▲

Use an appropriate disinfectant. All articles and surfaces must be thoroughly cleaned, rinsed with sterile water, and rough-dried.

Warning Alcohol, even a 70% solution, is volatile and flammable. Use it only in a well-ventilated area that is free from open flame. If any component is cleaned with alcohol, do not expose the component to open flame or other possible hazard. Do not spray the T/C sensor with flammable solutions. The internal temperature of the CO₂ sensor is approximately 150°C when the unit is in operation. Allow sufficient time for the sensor to cool before cleaning.

Do not use strong alkaline or caustic agents. Stainless steel is corrosion resistant, not corrosion-proof. Do not use solutions of sodium hypochlorite (bleach) as they may also cause pitting and rusting. ▲

A HEPA filter replacement kit (see Parts List) should be on-hand prior to cleaning the incubator interior.

1. Remove the shelves, access port filter assembly, HEPA filter, air sample filter and tubing, and the left and right duct sheets. Discard the HEPA filters and the access port filter assembly. See Figure 5-1.

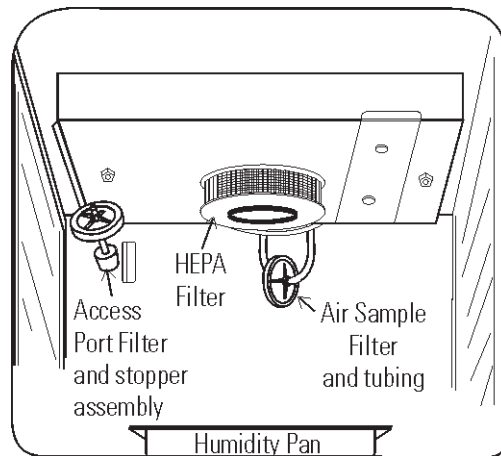

Figure 5-1. Component Locations

2. Wash the air sample filter tubing, shelves, and ducts with disinfectant, then rinse with sterile water. Optionally, the shelves and ducts may be autoclaved.
3. Wash the inner door gasket with disinfectant. This gasket may be removed to be cleaned, or replaced.
4. Wash the cabinet interior with disinfectant, starting at the top and working down. Refer to the disinfectant directions for length of time needed before rinsing. Wash the inner door both inside and out. The cabinet and door must be rinsed with sterile water until the disinfectant has been removed. After the cabinet has been rinsed, spray with 70% alcohol.
5. Install the left and right ducts, inner door gasket, access port filter assembly, and air sample filter and tubing, spraying each with 70% alcohol.
6. Install a new HEPA filter.
7. Install the shelves and spray with 70% alcohol.

Clean Cabinet Exterior

Clean the incubator exterior with a damp sponge or soft, well-wrung cloth and mild detergent dissolved in water. Dry with a soft cloth.

Clean Glass Doors

The chamber glass door and the optional independent inner glass doors may be cleaned using the same disinfectant as used on the incubator interior. It is imperative that they be rinsed with sterile distilled water to remove the disinfectant residue. The doors should then be dried with a soft cloth.

Some precautions in the cleaning and care of the incubator glass doors: Moisture leaches alkaline materials (sodium, Na) from the surface of the glass. Evaporation of the moisture concentrates the alkaline and may produce a white staining or clouding of the glass surface. Cleaning chemicals with a PH above 9 and heat (autoclaving) accelerate the corrosion process. Therefore, it is very important to rinse and dry the glass doors after cleaning. Autoclaving the glass doors should be avoided.

There is no simple method for repairing corroded glass. In most cases, the glass must be replaced.

Clean Humidity Pan

Clean the humidity pan with soap and water and a general-use laboratory disinfectant. Rinse with sterile water and spray with 70% alcohol. The pan may be autoclaved.

HEPA Filter Maintenance

Replace the HEPA filter when the REPLACE HEPA reminder is displayed. The REPLACE HEPA reminder can be set to alarm after a specified time from 1 to 12 months. The reminder default is the factory recommended setting of 6 months. For details, see Section 3.

Replace Power Fuses

To access the only replaceable fuse in the incubator:

1. Turn off the incubator's power switch and unplug the power cord.
2. Remove the two screws from the top of the control panel. Grasp the control panel on each side and pull straight outward.
4. Figure 5-3 shows the location of the fuse. See Table 5-1 following for replacement fuse specifications.
5. Secure the control panel and return the unit to service. If the fuse blows after restoring power to the incubator, contact the Technical Services Department.

Table 5-1. Fuse Replacement Chart

Fuse Voltage	Manufacturer's P/N	Amperage Rating	Rupture Speed	IEC Letter Code
115V ACC	BUSS GMC-1.0A	1.0 Amp	Time-Lag	T

Replace Air Sample Filter

1. Connect one end of the air sample filter to the hose barb on the chamber ceiling.
2. Connect the other end of the filter to the metal tubing on the HEPA filter adapter (Figure 5-2).

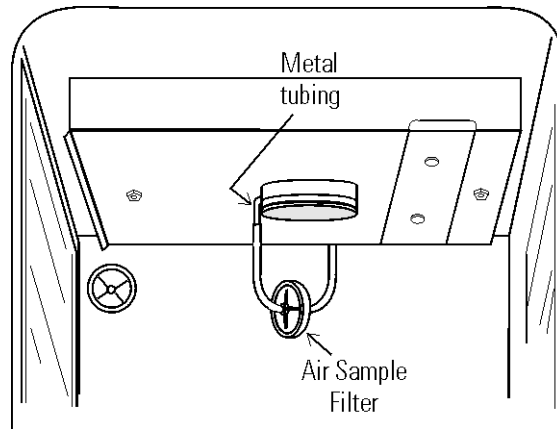

Figure 5-2. Connect to Metal Tubing

Electronics Section

1. Turn off the incubator's power switch and unplug the power cord.
2. Remove the three screws from the back of the cabinet top.
3. Slide the top backward about an inch and lift it off.

Major Components

Refer to Figure 5-3. Some components shown are factory installed options.

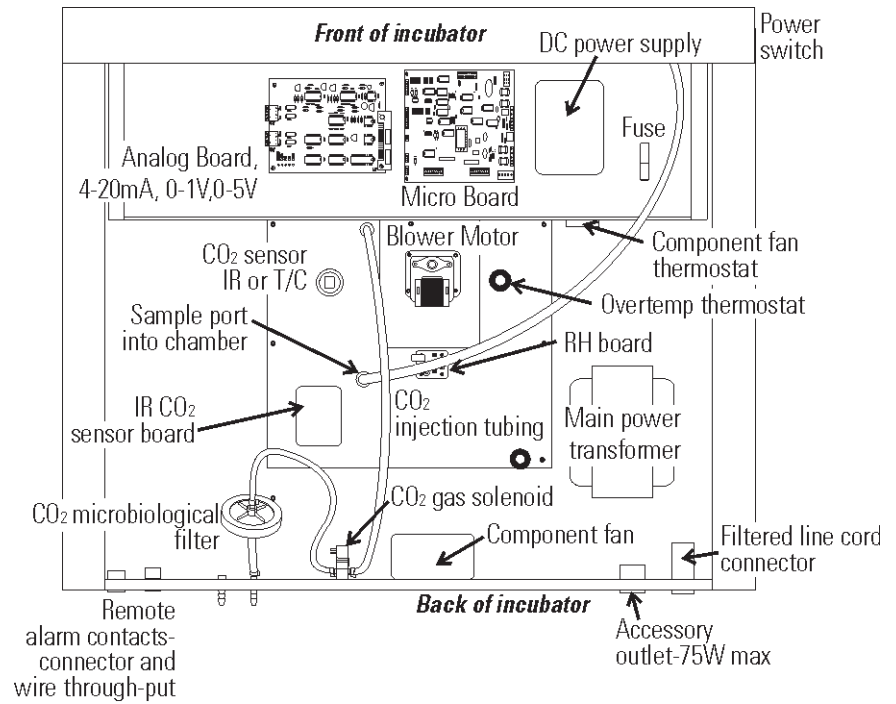

Figure 5-3. Electronics Drawer

Sterilization Cycle

Information You Need to Know Before Starting a Cycle

- The Sterilization Cycle requires approximately 12 hours - heat-up (2-4 hours), sterilize (2 hours), and cool down (6-8 hours). Additional time is needed to verify the calibration of temperature and CO₂ after the cycle is complete.
- During the Sterilization Cycle, the incubator updates the temperature to the analog output board and the 1535, however CO₂ will be fixed at setpoint and RH will be fixed at RH Low Limit plus 1%.
- A HEPA filter replacement kit (see the spare parts list) should be on hand prior to initiating the Sterilization Cycle.

Information About the Cycle

- Pre-cleaning may be required. In order to avoid odors, stains on the interior, baked-on material, etc., wipe off all visible signs of spills.
- Odor may occur during the Sterilization Cycle and is considered normal.
- The Steri Cycle is not intended to sterilize other items; instruments, etc., from the lab.
- During the cycle, the unit chamber becomes hot enough to melt samples, instruments, dishes, etc., left inside the unit. The items listed below also need to be removed.

- 1) HEPA filter
- 2) Air sample filter
- 3) Access port filter assembly
- 4) Water in the humidity pan
- 5) Temp/RH recorder probe, if applicable
- 6) IR sensor, if applicable

- During the Sterilization Cycle, discoloration of some materials may occur. For example, stainless steel turns a straw color after a period of exposure to high temperatures. This is normal.

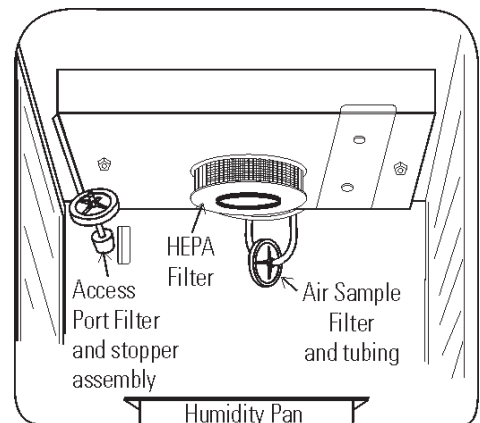

Checkpoints

What if?	Then
Cycle does not initiate or terminates in mid-cycle	Check for alarms: SYS IN OTEMP, AIR SNSR ERR, TMP CTRL ERR
Units are stacked	A Sterilization Cycle performed on either unit affects performance on second unit.. Do not use second unit during Sterilization Cycle. The Sterilization Cycle may be performed on both units simultaneously, with proper electrical connection.
No action is taken within 1 minute, following display prompt	Unit returns to normal operation, SYSTEM OK
Need to cancel cycle in progress	Hold down green cycle initiation button for 3 seconds
Water is not removed from humidity pan during cycle	Steam is produced and may cause burns
Listed components are not removed before initiating cycle	Components cannot withstand the sterilization cycle temperatures and are destroyed
Unit is not powered off before removing the I/R sensor, if applicable	Damage to the sensor may result
Dummy I/R sensor is not installed	The sensor cable cannot withstand sterilization cycle temperatures and is destroyed properly
The outer door is opened during the heat or sterilization phases	An outer door alarm occurs: CLOSE DOOR in the display, plus an audible (cannot be silenced) and visual alarm.
The outer door is open longer than 20 seconds during phases listed above	Cycle is canceled, unit goes to CANCELED COOL PHASE*
The outer door is open during the cool down phase when the temp is 60°C or greater	An outer door alarm occurs
Power interruption during the HEAT PHASE	HEAT PHASE resumes if the chamber temperature was less than 90°C when power was interrupted HEAT PHASE resumes if the chamber temperature was greater than 90°C when power was interrupted, and the temperature dropped less than 1°C CANCELED COOL PHASE* starts if the chamber temp drop is more than 1°C
Power interruption during the STERILIZATION PHASE	HEAT PHASE begins if the chamber temperature has not dropped below 139°C STERILIZATION PHASE starts again when the chamber temperature reaches 140°C CANCELED COOL PHASE* starts if the chamber temp dropped below 139°C

* For further information on CANCELED COOL PHASE, see page 5-12.

Sterilization Cycle

Warning The Sterilization Cycle heats the incubator interior surfaces to 140°C. Contact with any surface inside the outer door during this cycle may result in burns. ▲

1. Empty the water from the humidity pan and place the pan back into the incubator. Remove any samples, instruments, dishes, etc. from the chamber.
2. Press and hold the large white sterilization cycle button on the right side of the unit (Figure 5-4) for approximately 3 seconds until the LED lights.

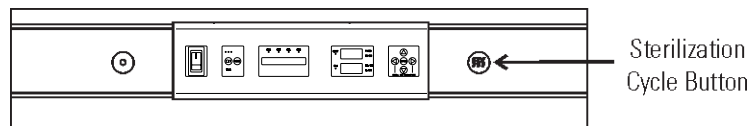

Figure 5-4. Sterilization Button Location

3. ENTER the access code, if applicable. An access code is recommended to prevent accidental cycle initiation.
4. **Pre Sterilization with T/C CO₂ sensor** - The display toggles between “REMOVE HEPAs”, “REMOVE WATER” and “PRESS ENTER”. If ENTER is not pressed within 1 minute, the display returns to “SYSTEM OK”.
5. Remove the HEPA filter, air sample filter and access port filter assembly (Figure 5-5). Tubing can remain in the unit during the sterilization cycle. In addition, remove the temp/RH recorder probe and IR sensor, if applicable. Discard the filters.

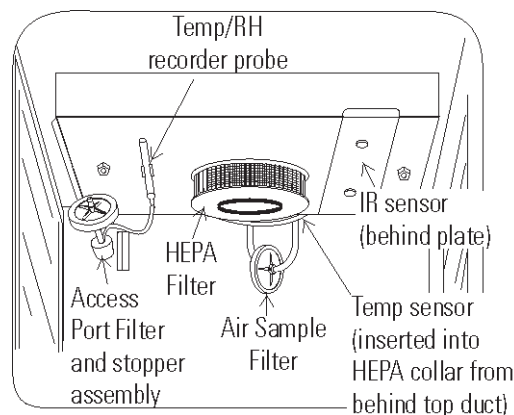

Figure 5-5. Filter Locations

Pre Sterilization with IR CO₂ sensor - If an IR sensor is connected, the display toggles between “POWER OFF” and “REMOVE IR”. If power is not turned off within 1 minute, the display returns to “SYSTEM OK”.

Note To remove the IR sensor, if applicable, first power the unit off. Then turn the two 1/4-turn fasteners on the top duct until the cover plate is disengaged. Secured on the inside of the plate is a dummy sensor (Figure 5-6). ▲

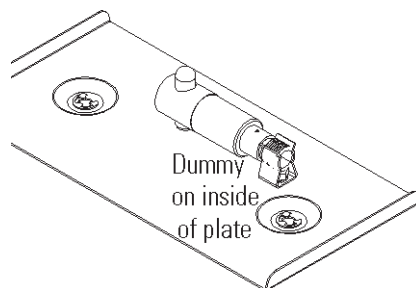

Figure 5-6. Dummy Sensor

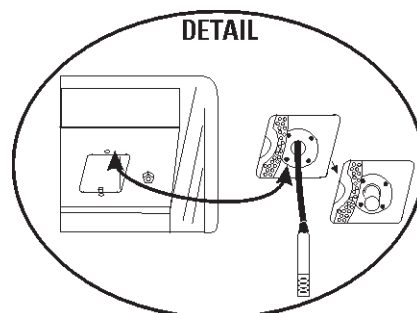

Figure 5-7. IR Sensor with Cable

Grip the IR sensor and carefully pull it downward. Unscrew the cable from IR sensor (Figure 5-13). Set the sensor aside. See Step 9 for the IR sensor disinfection procedure. Connect the dummy sensor to the cable. Fit the installed dummy sensor up into the previous sensor location.

When the power is turned on with the IR sensor removed, the display toggles between “REMOVE HEPAs”, “REMOVE WATER”, and “PRESS ENTER”. If “ENTER” is not pressed within 1 minute, the display toggles between “POWER OFF” and “REPLACE IR”. When the unit is powered back on with the IR sensor reinstalled, the display returns to “SYSTEM OK”.

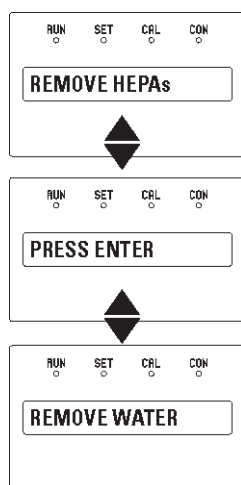

Figure 5-14. Displays with IR Sensor Removed

6. After ENTER is pressed, the Heat Phase initiates. The white LED flashes and the display toggles between “STERILIZING” and “HEAT PHASE”. During this period, the HEAT light will be on and the cabinet heats to sterilization temperature.

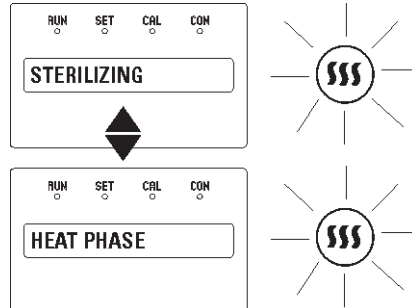

Figure 5-15. Heat Phase

7. When the air temperature in the unit reaches 140.0°C, the Sterilization Phase begins and the display changes to “STERILIZING”.

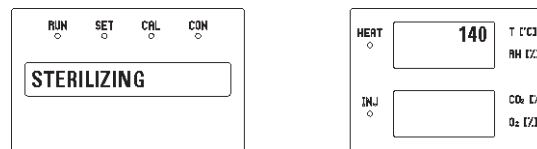

Figure 5-16. Sterilization Phase

8. After approximately 2 hours, a 5-second audible tone sounds, signaling that sterilization is complete. The Cool Phase begins. The display toggles between “STERILIZING” and “COOL PHASE”.

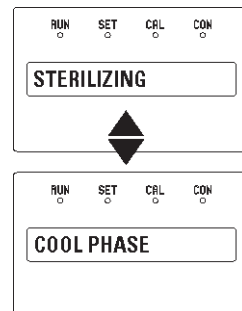

Figure 5-17. Cool Phase

9. **Completed Sterilization Cycle with T/C CO₂ sensor** - When the temperature cools down to the original set operating temperature or 30°C, whichever is higher, the display toggles between “CYC COMPLETE”, “REPL HEPAs”, and “PRESS ENTER”. The white LED is lighted but no longer flashes.

Completed Sterilization Cycle with IR CO₂ sensor - When the temperature cools down to the original set operating temperature or 30°C, whichever is higher, the display toggles between “CYC COMPLETE”, “POWER OFF”, and “REPLACE IR”. The white LED is lighted but no longer flashes.

Clean the IR sensor with either isopropanol or Lysol No-Rinse Sanitizer. When using isopropanol, simply spray the sensor (do not saturate) and allow to dry. With Lysol, spray the sensor (do not saturate) and allow to sit for a couple of minutes. Wipe dry with a clean, soft cloth.

Do not saturate the sensor or immerse the sensor in a cleaner.

Power the unit off, open the chamber, and remove the IR plate. Pull down on the dummy, unscrew the cable from the top of the dummy and press the dummy into the clip on the plate. See Figure 5-12. Screw the cable onto the top of the IR sensor. The cable is keyed and can only be inserted one way. Reinstall the sensor by pushing it as far as it will go into the hole.

After the unit is powered back on with the IR sensor reinstalled, the display toggles between “CYC COMPLETE”, “REPL HEPAs”, and “PRESS ENTER”.

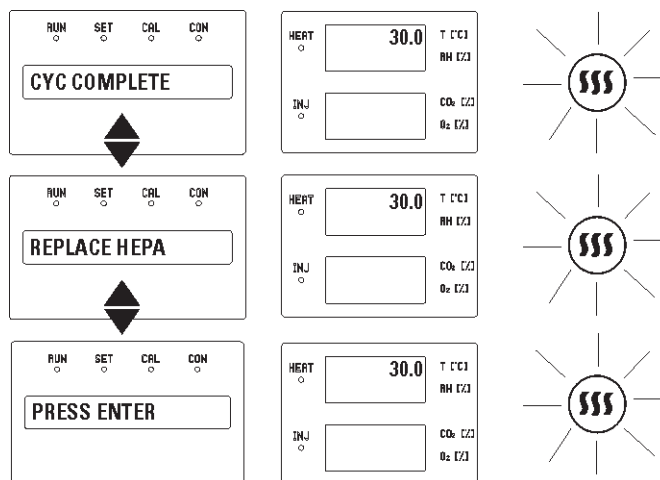

Figure 5-18. IR Sensor Reinstalled

10. Open the chamber and install a new HEPA filter, air sample filter and access port filter assembly. Press ENTER.
11. When ENTER is pressed, the LED goes out, the display returns to “SYSTEM OK”, and the HEPA filter replacement timer is reset.
12. Fill the humidity pan with 3 liters of sterile distilled water with the recommended purity range (See Section 1).
13. Allow to stabilize for at least 12 hours at the required temperature and CO₂ level. It is recommended that the temperature and CO₂ calibrations be verified periodically during the first week of returning the unit to service.

Caution The high temperature sterilization cycle may cause the T/C CO₂ sensor output to change significantly. (This is normal and does not indicate damage to the sensor.) Therefore it is essential that the CO₂ calibration is verified before returning the unit to service. ▲

If an independent instrument is not available to verify calibration, the following procedure may be performed. After the Sterilization Cycle and before CO₂ is allowed to enter the cabinet;

- 1) Fill and install the humidity pan.
- 2) Allow to stabilize at the desired operating temperature for at least 12 hours.
- 3) Calibrate the display to 0.0%.

Note If the Cool Phase is canceled, the display toggles between “CYC CANCELED” and “COOL PHASE”.

- With T/C CO₂ sensor - When the temperature cools down to the original set operating temperature or 30°C, whichever is higher, the display toggles between “CYC CANCELED”, “REPL HEPAs”, and “PRESS ENTER”. The white LED is lighted but no longer flashes.
- With IR CO₂ sensor - When the temperature cools down to the original set operating temperature or 30°C, whichever is higher, the display toggles between “CYC CANCELED”, “POWER OFF”, and “REPLACE IR”. The white LED is lighted but no longer flashes. After the unit is powered back on with the IR sensor reinstalled, the display toggles between “CYC CANCELED”, “REPL HEPAs” and “PRESS ENTER”.

Section 6 Factory Options

A description of the factory option connections to external equipment follows.

Remote Alarms

A set of relay contacts is provided to monitor alarms through an RJ11 telephone style connector on the back of the cabinet. Refer to Figure 6-5 for the location of the alarm connector. The 12-foot telephone cord (P/N 190388) and RJ11-to-screw terminal conversion box (P/N 190392) are available through the Technical Services department.

The remote alarm provides a NO (normally open) output, an NC (normally closed) output and COM (common). Refer to Figure 6-1.

The contacts will trip on a power outage or an overtemperature condition. The contacts may also be programmed to trip or not trip on temperature alarms, CO₂ alarms, and RH alarms. See Section 3, Configuration mode.

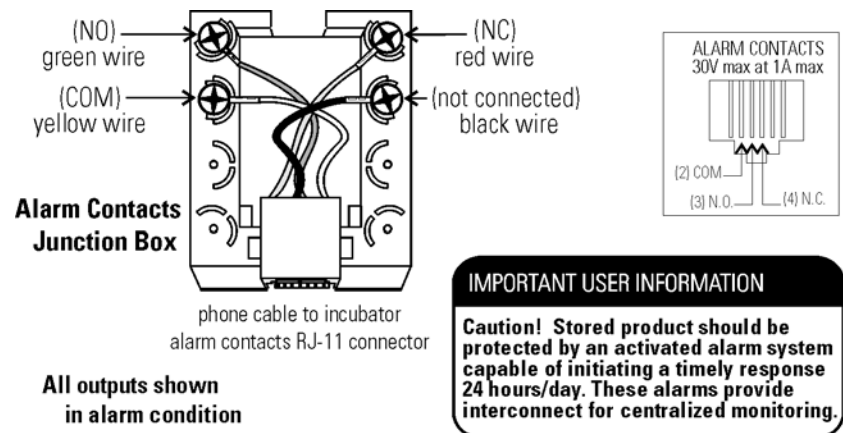

Figure 6-1. Remote Alarm Contacts



Humidity Readout

8000DH Series incubators are equipped with a humidity sensor to monitor the relative humidity inside the chamber. The sensor is located on the chamber ceiling and provides a signal that is displayed in 1% increments on the control panel. The humidity readout can display continuously, or toggle with the temperature readout. In addition, a low alarm limit can be set on the humidity readout to detect when the humidity pan runs dry. Refer to Section 3, Configuration.

The sensor is capable of measuring relative humidity from 10% to 100% with an accuracy of $\pm 5\%$ above 90%. See Section 2, Calibration, for details on calibrating the humidity readout.

Factors which may affect humidity levels in the chamber are: the water level in the humidity pan, frequency of door openings, and the fact that the humidity pan is located on the bottom of the chamber versus on a shelf.

Caution Incubators equipped with a T/C (thermal conductivity) CO₂ sensor rely on a constant level of relative humidity to accurately measure and control the CO₂ concentration in the incubator. ▲

Section 7 Specifications

*Specifications are based on a nominal voltage of 115V in ambients of 22°C to 25°C.

Temperature

Control $\pm 0.1^{\circ}\text{C}$ Microprocessor PID Control
Setpoint Digital - Touch pad, 0.1°C
Range $+5^{\circ}\text{C}$ above ambient to 50°C
Uniformity $\pm 0.3^{\circ}\text{C}$ @ $+37^{\circ}\text{C}$
Tracking alarm. . User programmable (low) indicator
Overtemp . . Tracking, user programmable, action, and indicator
Display Digital, LED, 0.1°C increments

Temperature Safety

Type . . . Extreme temperature safety, action, and indicator
Sensor . . Thermostat, independent of temp control system
Indicator . Message center, audible and visual alarms

Relative Humidity

Control Humidity pan - natural vaporization
Humidity w/ pan 95% RH at 37°C
Display Optional in 1% increments
Alarm Low RH with optional RH monitor

CO₂

Control $\pm 0.1\%$ microprocessor PID control
Sensor T/C or IR
Readability 0.1%
Range 0 to 20%
Inlet pressure 15 psig
Display Digital LED, 0.1% increments

Shelves

Dimensions 18.5" x 18.5" (47cm x 47cm)
Construction Stainless steel (belt sanded, both sides)
Surface area 2.4 sq. ft. per shelf
Max. per chamber 36.0 sq. ft.
Standard 4 (15 max.)

Construction

Interior volume6.5 cu. ft.
InteriorType 304 stainless steel shiny finish
Exterior18 gauge cold roll steel
Outer door gasket . .Four-sided molded, magnetic Santoprene
Inner door gasketBulb, silicone
InsulationMineral wool

Fittings

Access port1-1/4 inch removable silicone plug
CO₂ inlet1/4" barbed
Sample portFront mounted barbed

Electrical

115 Volt models
.115VAC, 50/60 Hz, 1PH, 9.6 FLA
(Operating range 90-125VAC)
230 Volt models
.230VAC, 50/60 Hz, 1 PH, 4.4 FLA
(Operating Range 180-250VAC)
Power switch/circuit breaker 2 Pole, 12.0 Amp
Accessory outlet . . .Voltage equal to the cabinet input.
75 Watts maximum, 0.5ma leakage current
Alarm contacts . . .Deviation of temperature, CO₂, power, NO and NC

Dimensions

Exterior26.1" W x 39.5" H x 25.0" F-B
.(66.3cm x 100.3cm x 63.5cm)
Interior21.3" W x 26.8" H x 20.0" F-B
.(54.0cm x 68.1cm x 50.8cm)

Weight

Net260 lbs (118kg)
Net shipping315 lbs (143kg)

Certifications

Refer to the Declaration of Conformity at the end of this manual

Safety Specifications

Indoor Use Only

Altitude2,000 meters

Temperature5°C to 40°C

Humidity80% RH at or below 31°C,

.....decreasing linearly to 50% RH at 40°C

Mains Supply Fluctuations

Mains supply voltage fluctuations not to exceed $\pm 10\%$
of nominal voltage

Installation Category II¹

Pollution Degree 2²

Class of Equipment¹

1 Installation category (overvoltage category) defines the level of transient overvoltage which the instrument is designed to withstand safely. It depends on the nature of the electricity supply and its overvoltage protection means. For example, in CAT II which is the category used for instruments in installations supplied from a supply comparable to public mains such as hospital and research laboratories and most industrial laboratories, the expected transient overvoltage is 2500V for a 230V supply and 1500V for a 120V supply.

2 Pollution Degree describes the amount of conductive pollution present in the operating environment. Pollution degree 2 assumes that normally only non-conductive pollution such as dust occurs with the exception of occasional conductivity caused by condensation.

Section 8 Spare Parts

Part Number	Description
190699	Removable feather gasket
190670	Duct sheet and shelf channel kit
224175	Stainless steel shelf
190884	Stainless steel shelf and channels
191650	Micro board, (main control)
230135	Fuse, 1A, TD, 5 x 20mm (accessory outlet, 115V)
156117	Motor, 2-pole, 115VAC, 50/60 Hz
190793	Display board
290184	Probe, 2252 Ohm/25°C, 1/8 x2
130077	Stopper with 3/8" hole
290168	Thermal conductivity (T/C) type CO ₂ sensor
231204	Infrared type CO ₂ sensor
250087	CO ₂ valve kit with assorted fittings
965010	CO ₂ gas regulator
3166242	Gas shuttle switch
3050	External gas guard
950316	Wall clamp for CO ₂ bottle
231203	RH sensor assembly (1900091 RH display option)
230180	12A, DPDT circuit breaker switch (power)
400119	Switcher, 40W, 12, 5, -12V
196018	.34 position control to display ribbon cable
360239	Inner door switch
360230	Outer door switch
360236	Sterilization initiation switch
100115	Blower wheel
190985	Access port filter assembly
760210	Disposable in-line filters (10 filters)
770001	Disposable filter, 99.97% (CO ₂ line, air sample)
760175	HEPA filter, 5.5" diameter
760209	HEPA value pack (4 filters)
1900067	HEPA filter replacement kit
190650	Independent inner door kit
190666	Right hand door swing
1900063	Roller base
1900354	Control panel overlay
130096	Clean Stick (for water reservoirs, pans, and bottles)

DWG. NUMBER: 370-200-2-B

REV	ECN NO.	DATE	BY	CAD	APPD	DESCRIPTION OF REVISION
0	N/A	4/10/01	DCB	DCB		RELEASE FOR PRODUCTION

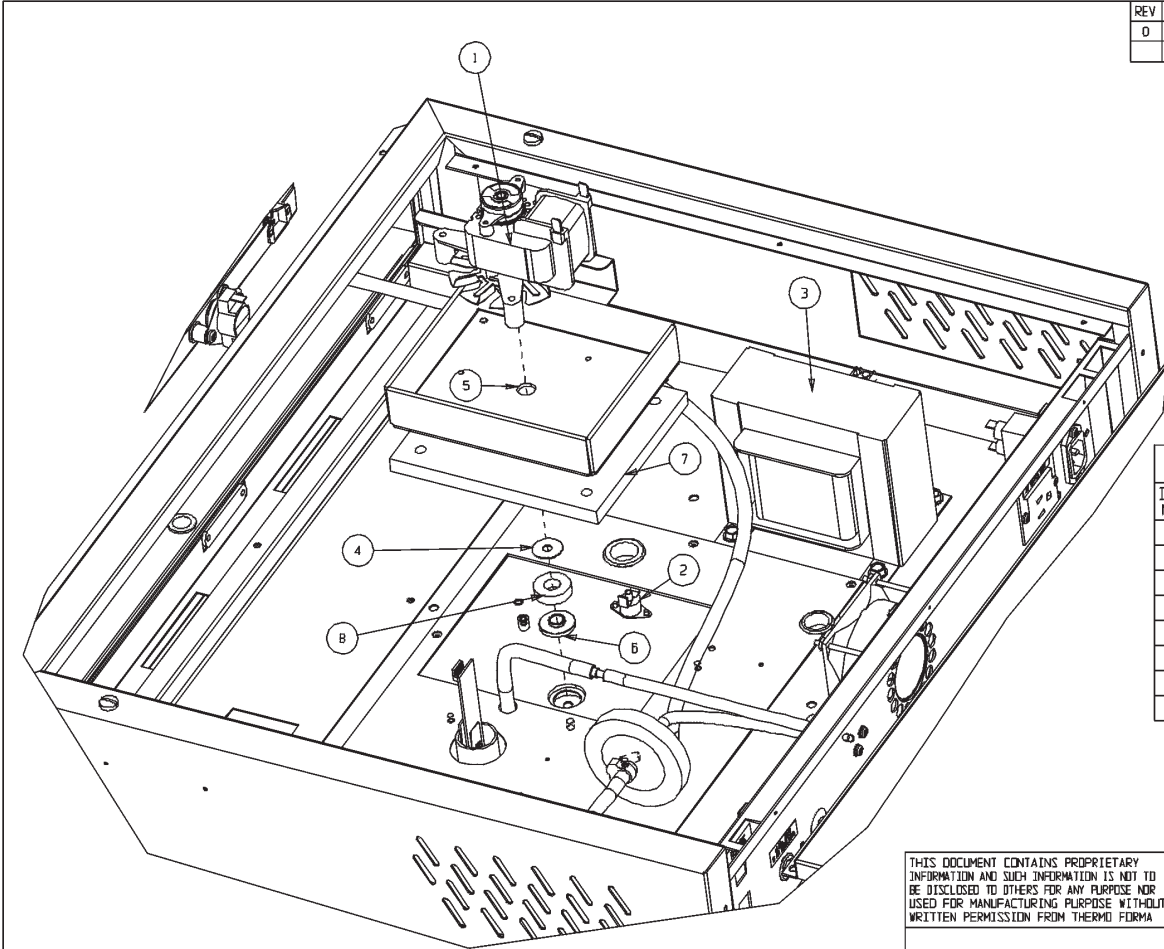

BILL OF MATERIALS

ITEM NO.	PART NO.	PART DESCRIPTION	QTY
1	156117	BLOWER MOTOR	1
2	400150	THERMOSTAT	1
3	420104	1 KVA TRANSFORMER	1
4	730077	TEFLON WASHER	2
5	1900302	MOTOR MOUNT	1
6	1900315	BLOWER SHAFT BUSHING	1
7	140300_PT3	BLOWER INSULATION 370 1 OF 3	1
8	730069_370	SILICONE WASHER	1

THIS DOCUMENT CONTAINS PROPRIETARY INFORMATION AND SUCH INFORMATION IS NOT TO BE DISCLOSED TO OTHERS FOR ANY PURPOSE NOR USED FOR MANUFACTURING PURPOSE WITHOUT WRITTEN PERMISSION FROM THERMO FORMA

MODEL/PART NAME: 370 SERIES STERI-CYCLE INCUBATOR					
DNG TITLE: ASSEMBLY					
DWN:	DALE	CAD:	DCB	APPD:	
DATE:	4/6/01	SCALE:	0.375		
MATERIAL: -					
PAINT: ANTIQUE WHITE					
TOLERANCE UNLESS OTHERWISE SPECIFIED				DRAWING NUMBER	SIZE
ANGLES:		DECIMAL: .XX±	370-200-2		B
		DECIMAL: .XXX±			

Thermo Forma
Box 649, Marietta, Ohio 45750

DWG. NUMBER: 370-200-3-B

REV	ECN NO.	DATE	BY	CAD	APPD	DESCRIPTION OF REVISION
0	N/A	4/11/01	DCB	DCB	DNF	RELEASE FOR PRODUCTION
1	IN-2942	05-14-01	DCB	KDG	LDN	REMOVED TOP ROW OF TABS FROM DUCT SHEET
2	IN-3124	07-30-03	JNL	KDG	CCS	CHANGED 290137 PROBE TO 290184

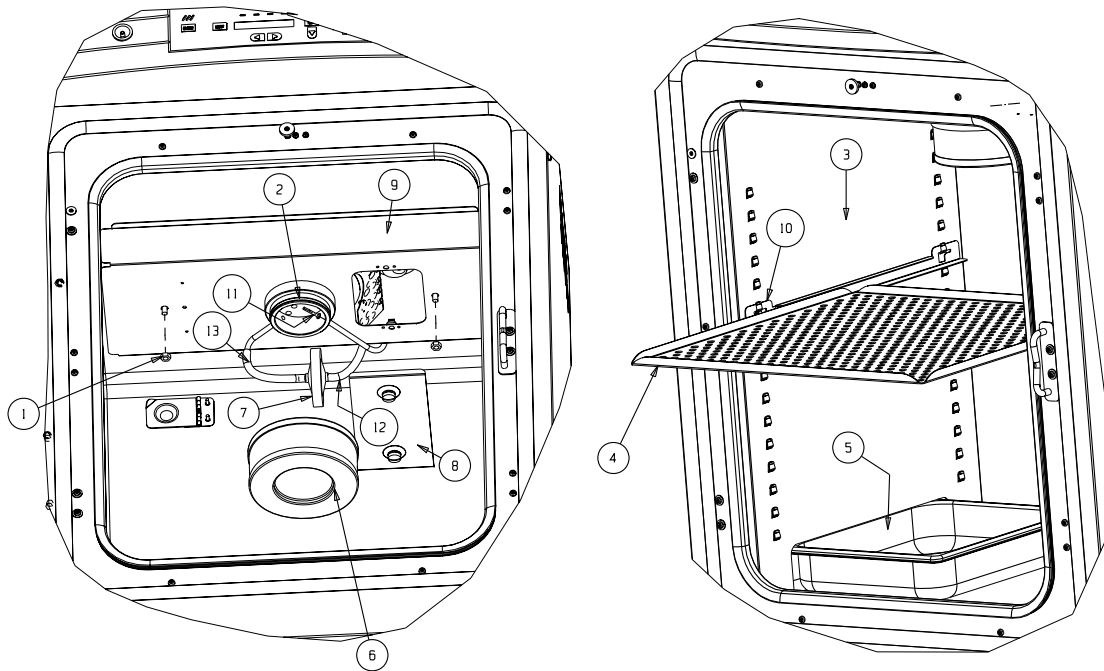

BILL OF MATERIALS

ITEM NO.	PART NO.	PART DESCRIPTION	QTY
1	23004	1/4-20 SS HEX NUT (4)	2
2	101013	3" SILICONE O-RING	1
3	190723	MODULAR W/J DUCT SHEET	2
4	224175	INC. SHELF - 2B BRUSHED BACK	1
5	237016	HUMIDITY PAN	1
6	760175	5.500" HEPIA FILTER	1
7	770001	DISPOSIBLE HEPIA FILTER 1/4 (8)	1
8	1900097	ACCESS PLATE	1
9	1900311	370 SERIES TOP DUCT SUB-ASSEMBLY	1
10	190664-31-1	SHELF CHANNEL	2
11	290184	TEMPERATURE SENSOR	1
12	FLTRD_AIR 2	244020 SILICONE TUBE 6"	1
13	FLTRD_AIR 3	244020 SILICONE TUBE 5"	1

THIS DOCUMENT CONTAINS PROPRIETARY INFORMATION AND SUCH INFORMATION IS NOT TO BE DISCLOSED TO OTHERS FOR ANY PURPOSE NOR USED FOR MANUFACTURING PURPOSE WITHOUT WRITTEN PERMISSION FROM THERMO ELECTRON CORPORATION		MODEL/PART NAME: 370 SERIES STERI-CYCLE INCUBATOR	
		DWG TITLE: ASSEMBLY	
DWN: DALE	CAD: DCB	APPD: DNF	DATE: 4/6/01 SCALE: 0.200
MATERIAL: -		DRAWING NUMBER: 370-200-3	
PAINT: WHITE		SIZE: B	
TOLERANCE UNLESS OTHERWISE SPECIFIED: ANGLES: .XX±		DECIMAL: .XXX±	



DWG. NUMBER: 370-200-4-B

REV	ECN NO.	DATE	BY	CAD	APPD	DESCRIPTION OF REVISION
0	N/A	4/11/01	DCB	DCB		RELEASED FOR PRODUCTION
1	IN-3124	07-30-03	JNL	KDG	CCS	CHANGED 290137 PROBE TO 290184

BILL OF MATERIALS			
ITEM NO.	PART NO.	PART DESCRIPTION	QTY
1	23051	#8-32 S.S. WING NUT	4
2	100115	VORTEX BLOWER WHEEL CW	1
3	127066	2.250" SPACER 1/4"-20	2
4	610075	1/4"-20 SS LEFT- HANDED NUT	1
5	730077	TEFLON WASHER	2
6	1900083	BRASS FAN ADAPTER	1
7	1900111	BLOWER WHEEL PLATE	1
8	1900320	CLASS 100 PLATE	1
9	1900322	ACCESS PORT FLAP ASSEMBLY	1
10	290184_370	TEMPERATURE SENSOR	1

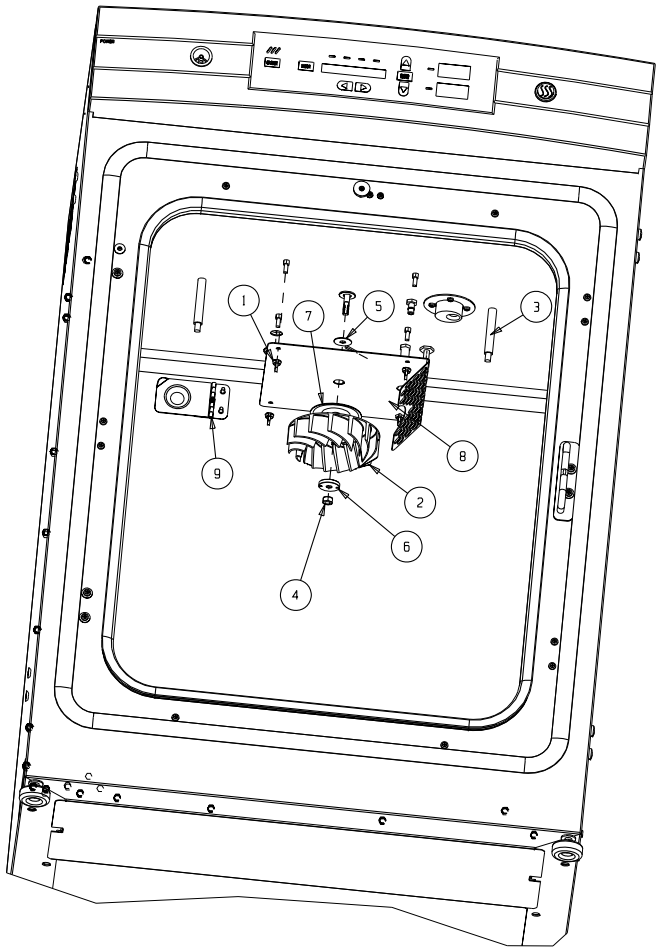

THIS DOCUMENT CONTAINS PROPRIETARY INFORMATION AND SUCH INFORMATION IS NOT TO BE DISCLOSED TO OTHERS FOR ANY PURPOSE NOR USED FOR MANUFACTURING PURPOSE WITHOUT WRITTEN PERMISSION FROM THERMO ELECTRON CORPORATION

MODEL/PART NAME: 370 SERIES STERI-CYCLE INCUBATOR					
DWG TITLE: ASSEMBLY					
DWN: DALE	CAD: DCB	APPD:	DATE: 4/6/01	SCALE: 0.218	
MATERIAL: -					
PAINT: WHITE					
TOLERANCE UNLESS OTHERWISE SPECIFIED			DRAWING NUMBER	SIZE	
ANGLES:	DECIMAL: .xx±	.xxx±	370-200-4	B	

Thermo
ELECTRON CORPORATION

DWG NUMBER: 370-200-5 -B

REV	ECN NO.	DATE	BY	CAD	APPD	DESCRIPTION OF REVISION
0	N/A	4/17/01	DCB	DCB	DNF	RELEASE FOR PRODUCTION
1	IN-2847	06/25/01	JRH	JRH	MSB	SWITCHED CO2 INLET TO OTHER HOLE
2	PIP-029	06-29-01	WCW	PKD	KDG	REVISED OUTLET MOUNT
3	SI-9181	05-19-04	GLM	KDG	CCS	CHG'D. 250085 CLIPPARD VALVE TO ASCO

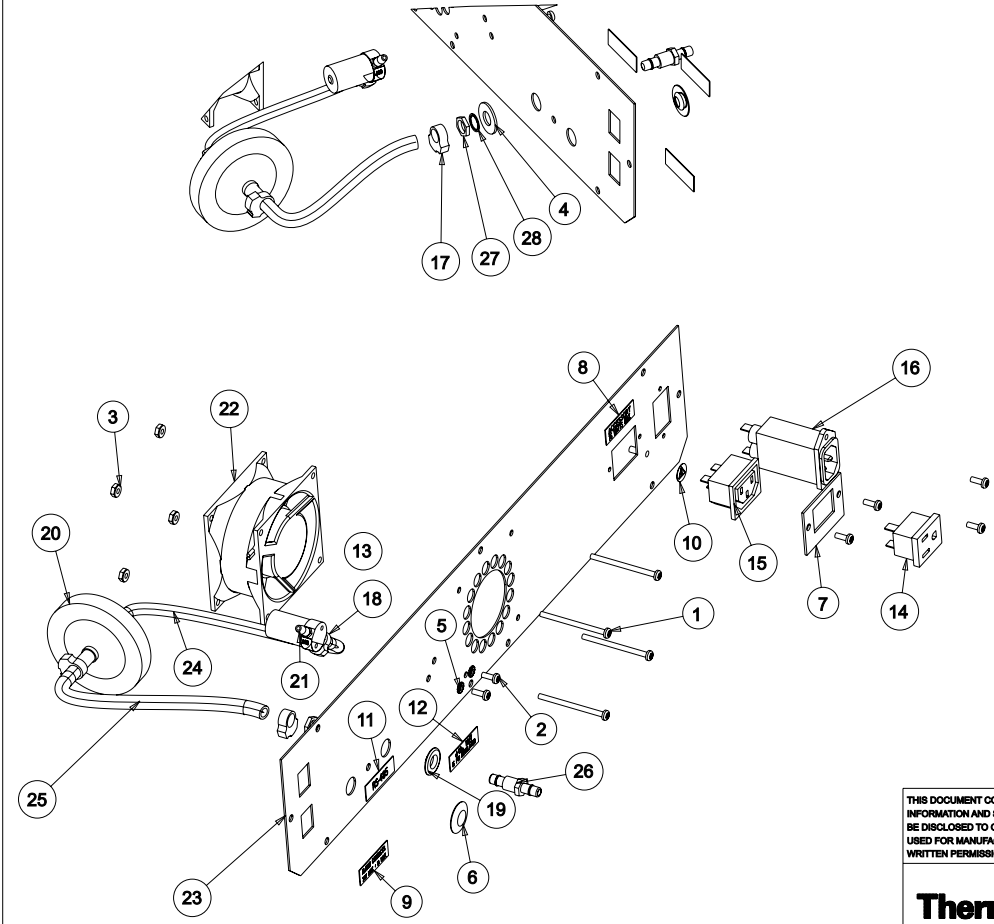

BILL OF MATERIALS

ITEM NO.	PART NO.	PART DESCRIPTION	QTY
1	22011	#6-32 x 2 SS PHP SCREW	4
2	22049	#6-32 X 3/8 SS PHP SCREW	6
3	23001	#6-32 ZP LKWASH HEX NUT	4
4	23024	3/8" SS FLAT WASHER	1
5	23058	#6 SS EXT TOOTH LOCKWASHER	2
6	34014	1/2" SNAP-IN HOLE PLUG (BLACK) (370/380 ONLY)	1
7	190994	ACCESSORY OUTLET MOUNT	1
8	220259	ACCESS OULET LABEL	1
9	220381	ALARM CONTACT LABEL	1
10	220490	REFER TO MANUAL LABEL	1
11	220565	RS-485 LABEL	1
12	220566	CO2 #1 LABEL (370/380 ONLY)	1
13	250085	SOLENOID VALVE 12V (371, 381 ONLY)	1
14	460024	SNAP-IN OUTLET, WHITE	1
15	460138	POWER OUTLET	1
16	460180	15 AMP RFI ENTRY	1
17	600034	SNAPPER CLAMP .375	3
18	600063	SNAPPER CLAMP .312	1
19	730044	SHOULDER WASHER .375" ID	1
20	770001	DISPOSABLE HEPA FILTER 1/4	1
21	840008	5/32 TUBING ADAPTER	2
22	900135	3.15" SQUARE FAN	1
23	1900313-16-1	BACK PANEL STUD DETAIL	1
24	370-CO2-INLET-2	72015 3/16" VINYL TUBING 6"	1
25	370_CO2_INLET_1	950013 VINYL INLET TUBE 370 , 8"	1
26	840020_FITTING	.250 BULKHEAD FITTING	1
27	840020_NUT	.375 NUT BULKHEAD FITTING	1
28	840020_WASHER	.375 IT WASHER BULKHEAD FITTING	1

THIS DOCUMENT CONTAINS PROPRIETARY INFORMATION AND SUCH INFORMATION IS NOT TO BE DISCLOSED TO OTHERS FOR ANY PURPOSE NOR USED FOR MANUFACTURING PURPOSE WITHOUT WRITTEN PERMISSION FROM THERMO ELECTRON

MODEL/PART NAME: 370 INCUBATOR
 DWG TITLE: 370 BACK PANEL ASSEMBLY
 DWN:DALE CAD: DCB APPD: DATE: 3/28/01 SCALE: 0.375



MATERIAL: -
 PAINT: N/A
 TOLERANCE UNLESS OTHERWISE SPECIFIED
 ANGLES: DECIMAL: .XX=%%p .XXX=%%p
 DRAWING NUMBER: 370-200-5
 SIZE: B

DWG. NUMBER: 370-200-6-B

REV	ECN NO.	DATE	BY	CAD	APPD	DESCRIPTION OF REVISION
0	N/A	3/28/01	DCB	DCB	DNF	RELEASED FOR PRODUCTION
1	1N-2994	10-25-01	WCW	PDK	LDN	CHG. FROM 22130 & 23029 TO 590032
2	1N-3048	09-25-02	GJG	KDG		ADDED (4) 515084 SPACERS

BILL OF MATERIALS			
ITEM NO.	PART NO.	PART DESCRIPTION	QTY
1	22015	#8-32 X 3/4 SS PHP SCREW	2
2	23002	#8-32 ZP LKWASH HEX NUT	3
3	23006	#4-40 ZP LKWASH HEX NUT	1
4	59007	#4-40 X 3/8 SS PHP SCREW	1
5	111037	NYLON WIRE SADDLE	2
6	120048	NYLON BEARING 1/4" X 7/16"	2
7	191650	370 SERIES INCUBATOR MICRO BOARD	1
8	220359	1 AMP FUSE LABEL	1
9	220488	.5 AMP FUSE	1
10	230105	FUSE BLOCK 5 X 22 MM	1
11	230120	FUSE_5A_5X22MM	1
12	230135	FUSE_1A_5X22MM	1
13	400119	SWITCHER	1
14	400151	THERMOSTAT 160 F	1
15	515084	1/4 DIA. X 3/8L SS SPACER	4
16	590032	#4-40 X 1/4 SS PHP EXT SEMS SCREW	8
17	610055	#8-32 CLIPNUT	4
18	730058	NYLON SHOULDER WASHER	4
19	1900312-15-1	COMPONENT TRAY SUB-ASSEMBLY	1

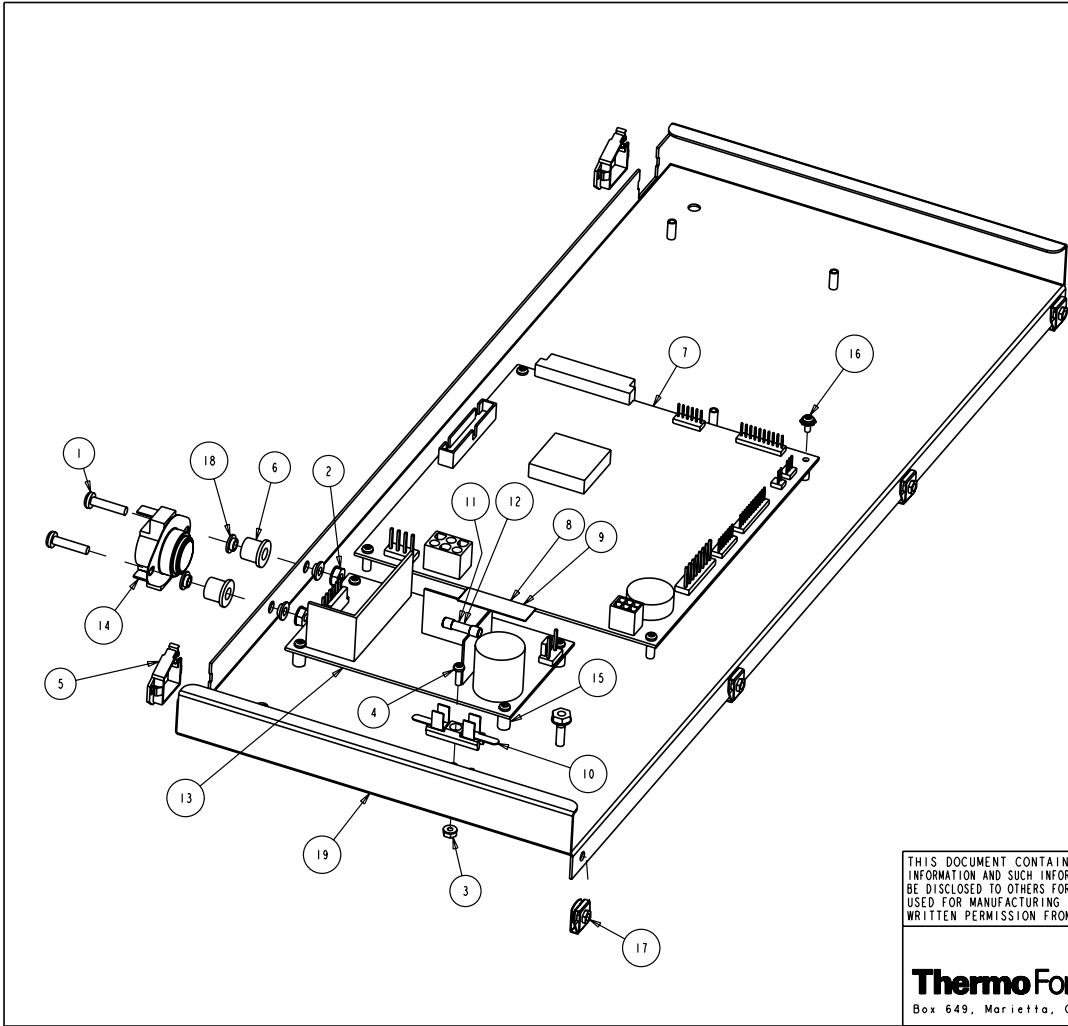

THIS DOCUMENT CONTAINS PROPRIETARY INFORMATION AND SUCH INFORMATION IS NOT TO BE DISCLOSED TO OTHERS FOR ANY PURPOSE NOR USED FOR MANUFACTURING PURPOSE WITHOUT WRITTEN PERMISSION FROM THERMO FORMA	MODEL/PART NAME: 370 SERIES INCUBATOR			
	DWG TITLE: CONTROL PANEL TRAY ASSY			
	DWN: DALE	CAD: DCB	APPD: LDN	DATE: 3/28/01
				SCALE: 0.500
	MATERIAL: -			
	PAINT: N/A			
	TOLERANCE UNLESS OTHERWISE SPECIFIED		DRAWING NUMBER	SIZE
	ANGLES:	DECIMAL: .XX±	370-200-6	B
		.XXX±		

Thermo Forma
Box 649, Marietta, Ohio 45750

DRAWING NUMBER: 3598-200-7-B

REV	ECN NO.	DATE	BY	CAD	APPD	DESCRIPTION OF REVISION
0	NA	06-30-06	GJG	GJG	CCS	RELEASED FOR PRODUCTION

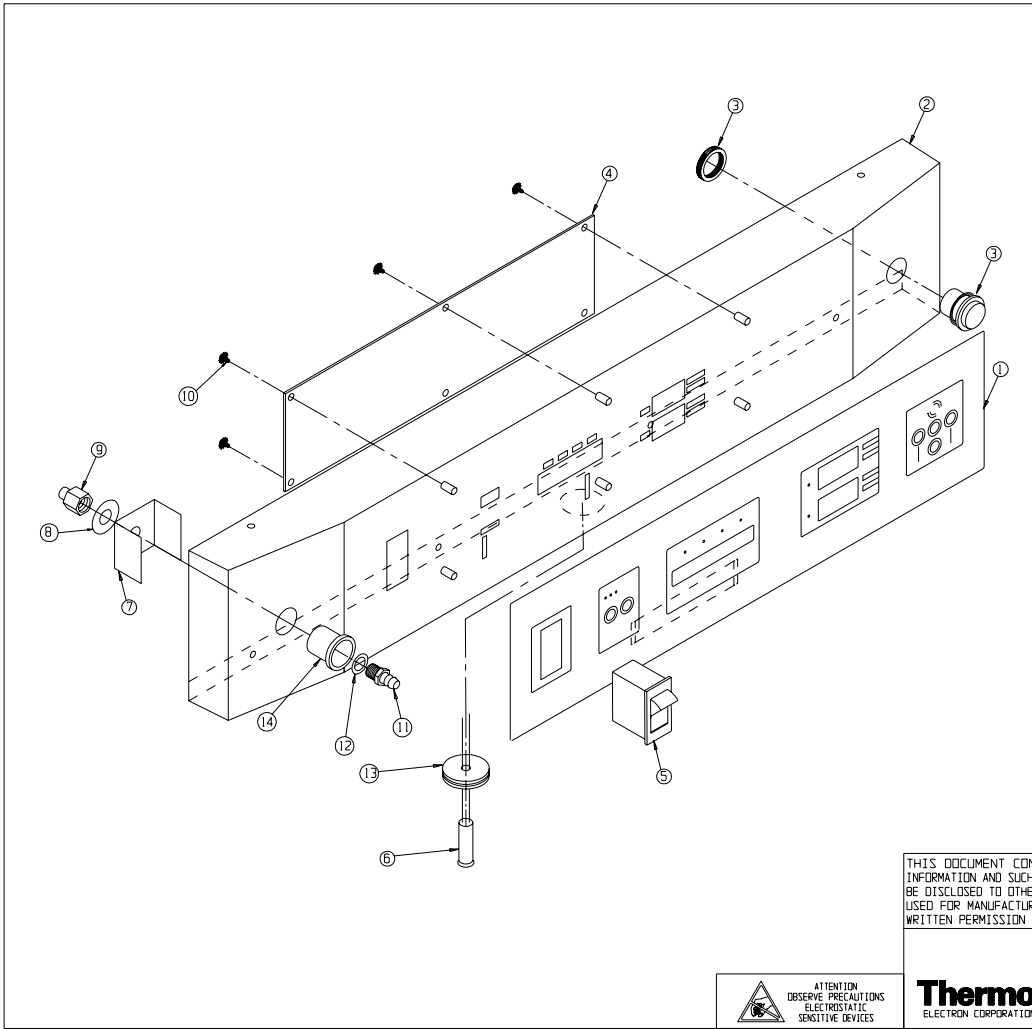

BILL OF MATERIALS

ITEM	PART NUMBER	PART DESCRIPTION	QTY
1	140387	CONTROL PANEL OVERLAY	1
2	1900277	CONTROL PANEL	1
3	360269	STERI CYCLE SWITCH (WHITE)	1
4	1900346	CONTROL CIRCUIT BOARD	1
5	230180	CIRCUIT BREAKER SWITCH 12A	1
6	360230	MAGNETIC OUTER DOOR SWITCH	1
7	1900355	SAMPLE PORT BRACKET	1
8	23024	3/8 SS FLAT WASHER	1
9	840065	1/4 HOSE X 1/8 FPT BRASS ADAPTER	1
10	590027	6-32 X 1/4 PHP SEMS SCREW	6
11	840035	3/16 HOSE X 1/8 MPT BRASS ADAPTER	1
12	730060	.416 ID X .628 OD SS WASHER	1
13	114011	1 1/4 OD X 1/4 ID GROMMET	1
14	190294	FILL PORT RECESS	1
15			
16			
17			
18			
19			
20			
21			

THIS DOCUMENT CONTAINS PROPRIETARY INFORMATION AND SUCH INFORMATION IS NOT TO BE DISCLOSED TO OTHERS FOR ANY PURPOSE NOR USED FOR MANUFACTURING PURPOSES WITHOUT WRITTEN PERMISSION FROM THERMO ELECTRON

MODEL/PART NAME: 3598 SERIES INCUBATOR
 DWG TITLE: CONTROL PANEL BEZEL ASSEMBLY
 DWN: GJG CAD: GJG APPD: DATE: 06-30-06 SCALE: .625



MATERIAL: NA
 PAINT COLOR: NA
 TOLERANCE UNLESS OTHERWISE SPECIFIED
 ANGLES: DECIMAL: .XX±
 DRAWING NUMBER: 3598-200-7
 SIZE: B

DWG. NUMBER: 370-200-8-B

REV	ECN NO.	DATE	BY	CAD	APPD	DESCRIPTION OF REVISION
0	N/A	04-24-01	DCB	DCB	LDN	RELEASED FOR PRODUCTION
1	IN-2915	07-06-01	JGL	KDG	LDN	ADDED 1900118 RING & NUTS TO TC SENSOR
2	IN-2967	09-27-01	JGL	KDG	LDN	TC SENSOR, ADDED 1900132 HEATER PLATE

BILL OF MATERIALS			
ITEM NO.	PART NO.	PART DESCRIPTION	QTY
1	22127	6-32 x1.250 SS PHP SCREW	4
2	23001	#6-32 ZP LKWASH HEX NUT	4
3	244112	CONVOLUTED TUBE	1
4	290168	HI-TEMP TC SENSOR	1
5	1900082	TEFLON TC MOUNT	1
6	1900118	BELLOWS RESTRAINING RING	1
7	1900132	370 TC HEATER PLATE	1
8	1900327	TC STOP RING	1
9	1900326-31-1	TC ADAPTER RING	1

BILL OF MATERIALS			
ITEM NO.	PART NO.	PART DESCRIPTION	QTY
1	22015	#8-32 X 3/4 SS PHP SCREW	4
2	23002	#8-32 ZP LKWASH HEX NUT	4
3	24030	#8 X 1/2" TEKS SCREW	2
4	30088	7/8" SNAP BUSHING	1
5	103034	GASKET	1
6	231204	IR SENSOR	1
7	231205	IR SENSOR MOUNT	1
8	244112	CONVOLUTED TUBE	1
9	1900340	IR STOP 370	1
10	1900325-31-1	IR ADAPTER RING	1

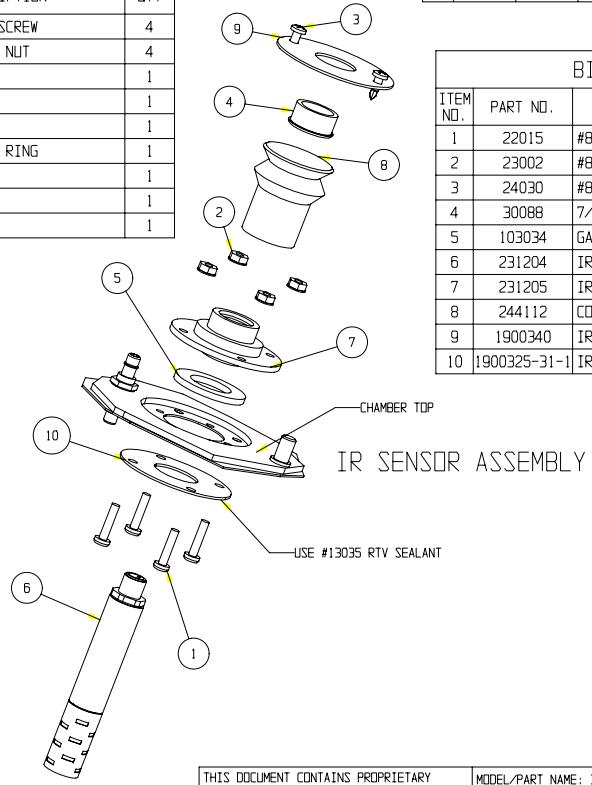
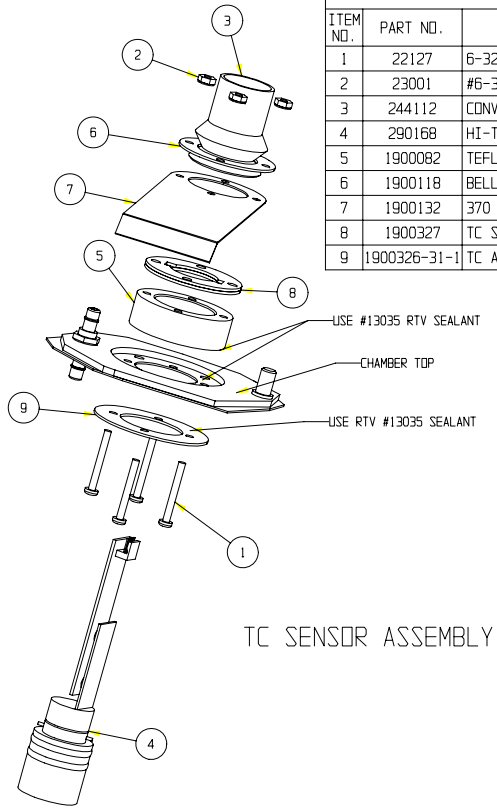

THIS DOCUMENT CONTAINS PROPRIETARY INFORMATION AND SUCH INFORMATION IS NOT TO BE DISCLOSED TO OTHERS FOR ANY PURPOSE NOR USED FOR MANUFACTURING PURPOSE WITHOUT WRITTEN PERMISSION FROM THERMO FORMA		MODEL/PART NAME: 370 SERIES INCUBATOR	
		DWG TITLE: CO2 SENSORS	
DWN: DALE	CAD: DCB	APPD: LDN	DATE: 3/27/01
MATERIAL: -		SCALE: 0.500	
PAINT: N/A		DRAWING NUMBER	SIZE
TOLERANCE UNLESS OTHERWISE SPECIFIED		370-200-8	B
ANGLES:	DECIMAL: .XX± .xxx±		

Thermo Forma
Box 649, Marietta, Ohio 45750

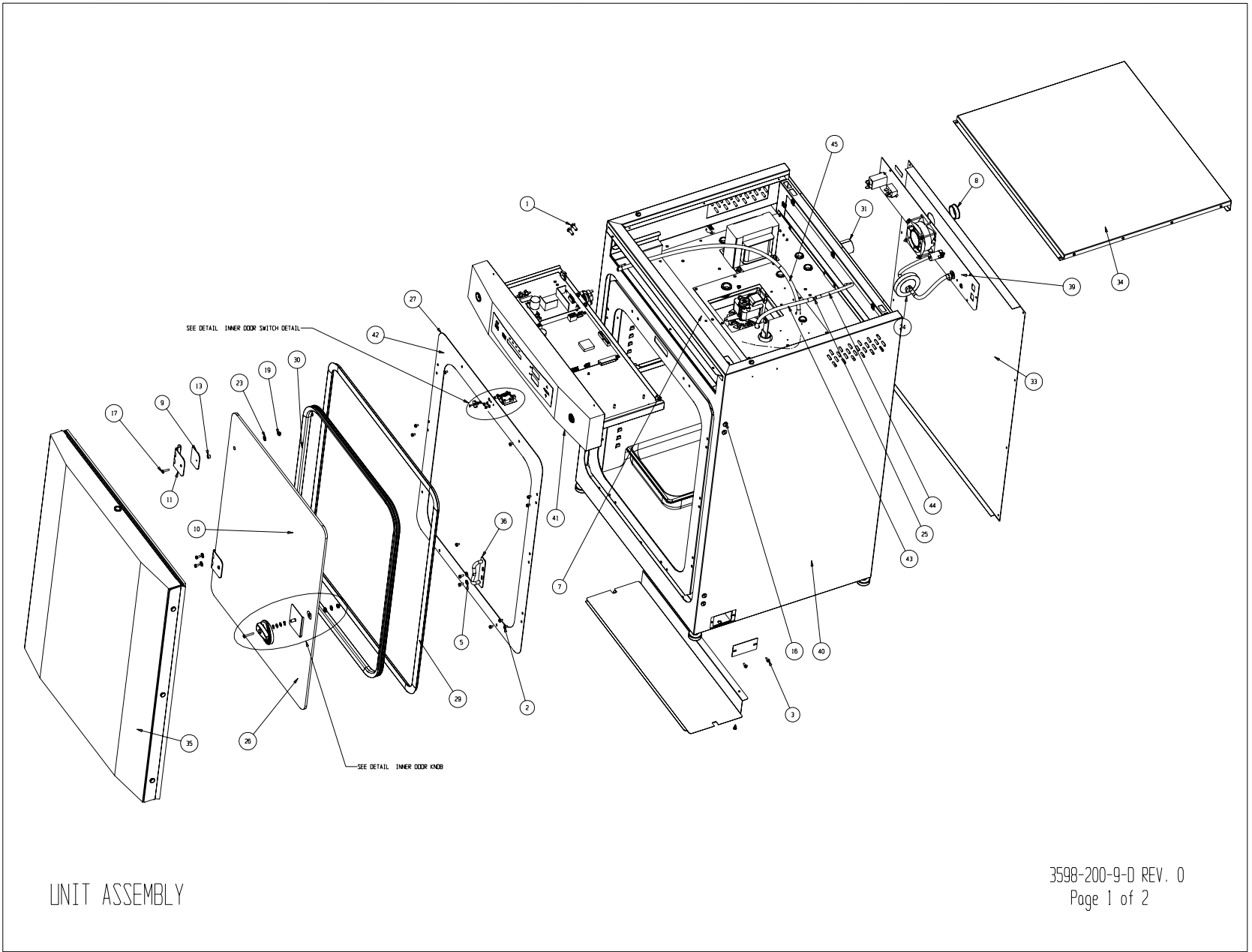

UNIT ASSEMBLY

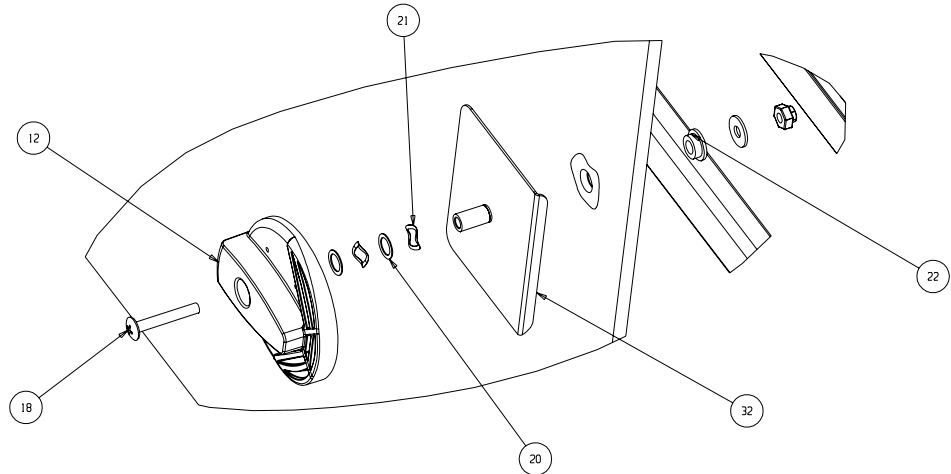

DETAIL INNER DOOR KNOB
SCALE 0.750

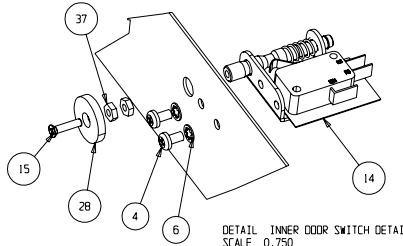

DETAIL INNER DOOR SWITCH DETAIL
SCALE 0.750

BILL OF MATERIALS

ITEM NO.	PART NO.	PART DESCRIPTION	QTY
1	20058	#1/4-20 X 3/4 SS FHP UC SCREW	4
2	22051	#8-32 X 1/4 SS PHP SCREW	10
3	22052	#8-32 X 3/8 SS PHP SCREW	5
4	22115	#6-32 X 1/4 SS PHP SCREW	2
5	23021	#8 SS FLAT WASHER	7
6	23030	#6 INTERNAL LOCK WASHER SS	2
7	23051	#8-32 S.S. WING NUT	4
8	30077	1-1/2" SNAP BUSHING	1
9	103115	INNER DOOR HINGE GASKET	2
10	105066	20.5 X 26.875 X .23 THK. TEMPER GLASS	1
11	116109	SS HINGE .693 HINGE HEIGHT	2
12	120072	ULTRA HIGH TEMP KNOB DETAIL	1
13	125022	TEFLON SPACER 11/32" O.D.	2
14	360239	INTERLOCK SWITCH	1
15	490026	4-40 X 1/2 FHP SS SCREW	1
16	550050	1/4-20 X 1/2" NYLON BH SCREW	6
17	550054	#8-32 X 3/4 TRUSS HD PHILLIPS SCREW	2
18	550055	#8-32 X 1-1/8 TRUSS HD PHILLIPS SCREW	1
19	610079	8-32 SS 'FLEXLOC' LOCKING NUT	3
20	730056	.285 ID SS FLAT WASHER	3
21	730057	WAVE WASHER .288" ID X .407 OD	2
22	730073	TEFLON SHOULDER WASHER	1
23	730086	1/2 OD SILICONE SEAL WASHER #8	2
24	770001	DISPOSIBLE HEPIA FILTER 1/4	1
25	840026	3/16" X 1/4" TUBING REDUCER	1
26	1900304	INNER DOOR ASSEMBLY	1
27	1900318	INTERIOR FRONT TRIM	1
28	1900338	3/4 O.D INNER DR SWITCH STRIKE	1
29	103102_370	HEATBREAK GASKET SILICONE	1
30	103108_370	INNER DOOR SILICONE GASKET	1
31	180115_6	PORT LINER, TEFLON STRIP 6"LONG	1
32	1900182-16-1	INNER GLASS DOOR KNOB PLATE W/HOLE MNT.	1
33	1900307-31-1	EXTERIOR BACK	1
34	1900308-16-1	TOP COVER ASSEMBLY	1
35	3582102-02-1	EXTERIOR DOOR ASSEMBLY	1
36	1900333-15-1	INNER DOOR STRIKE ASSEMBLY	1
37	23005A	#4-40 SS HEX NUT	2
38	290184_370	TEMPERATURE SENSOR	1
39	370-200-5	370 BACK PANEL ASSEMBLY	1
40	3701000-01-1	EXTERIOR WRAP ASSEMBLY	1
41	3578-71-1	FRONT CONTROL PANEL ASSEMBLY	1
42	3705000-01-1	INNER FACE PLATE ASSY	1
43	INJECT_TUBE_1	CO2 INJECT TUBE VINYL #72015 6"	1
44	INJECT_TUBE_2	CO2 INJECT TUBE #244020 10"	1
45	SMPL_TUBE_370	SAMPLE TUBE SILICONE #244020 30"	1

UNIT ASSEMBLY

3598-200-9-D REV. 0
Page 2 of 2

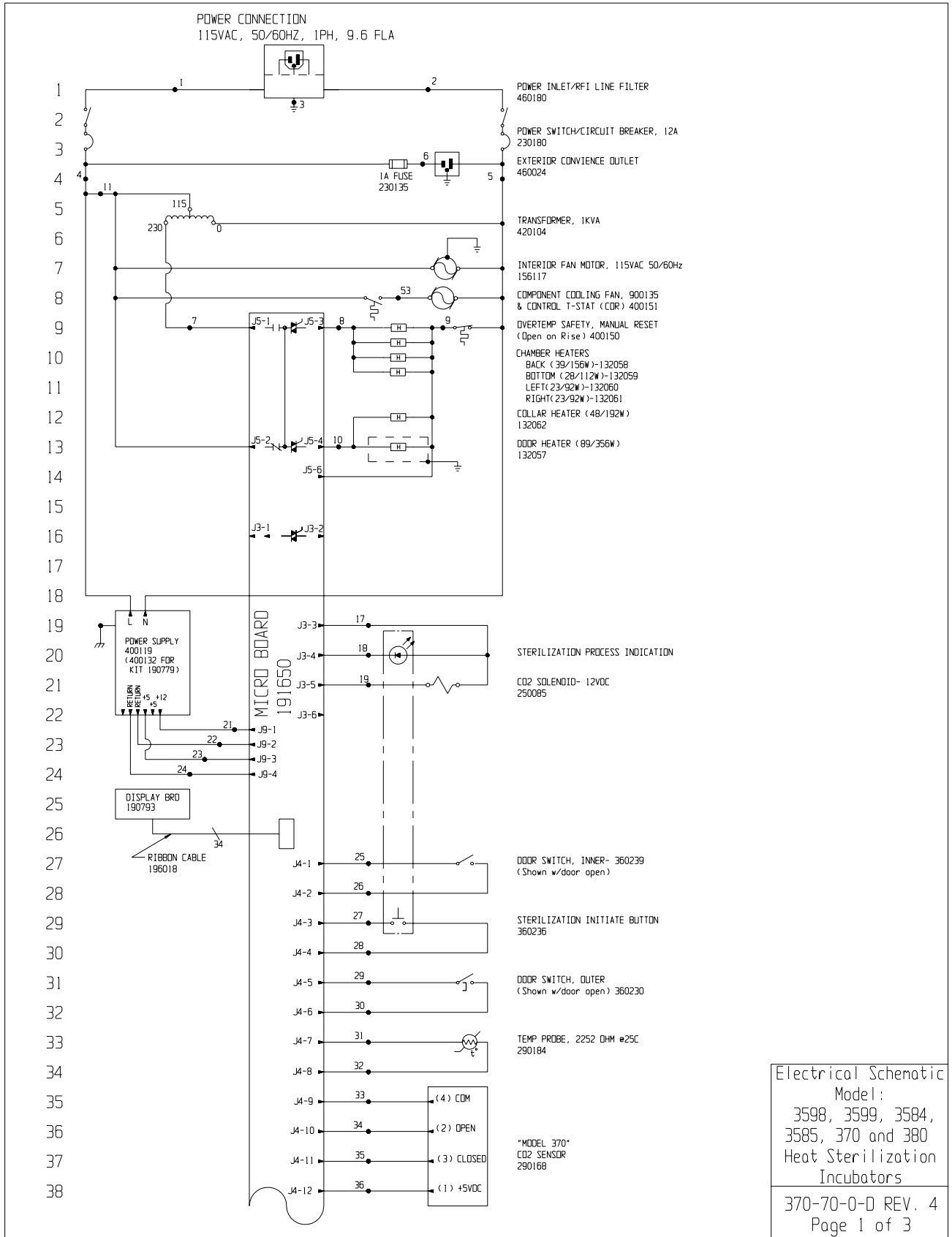

Electrical Schematic
Model:
3598, 3599, 3584,
3585, 370 and 380
Heat Sterilization
Incubators
370-70-0-0 REV. 4
Page 1 of 3

Section 9
Electrical Schematics

39
40
41
42
43
44
45
46
47
48
49
50
51
52
53
54
55
56
57
58
59
60
61
62
63
64
65
66
67
68
69
70
71
72
73
74

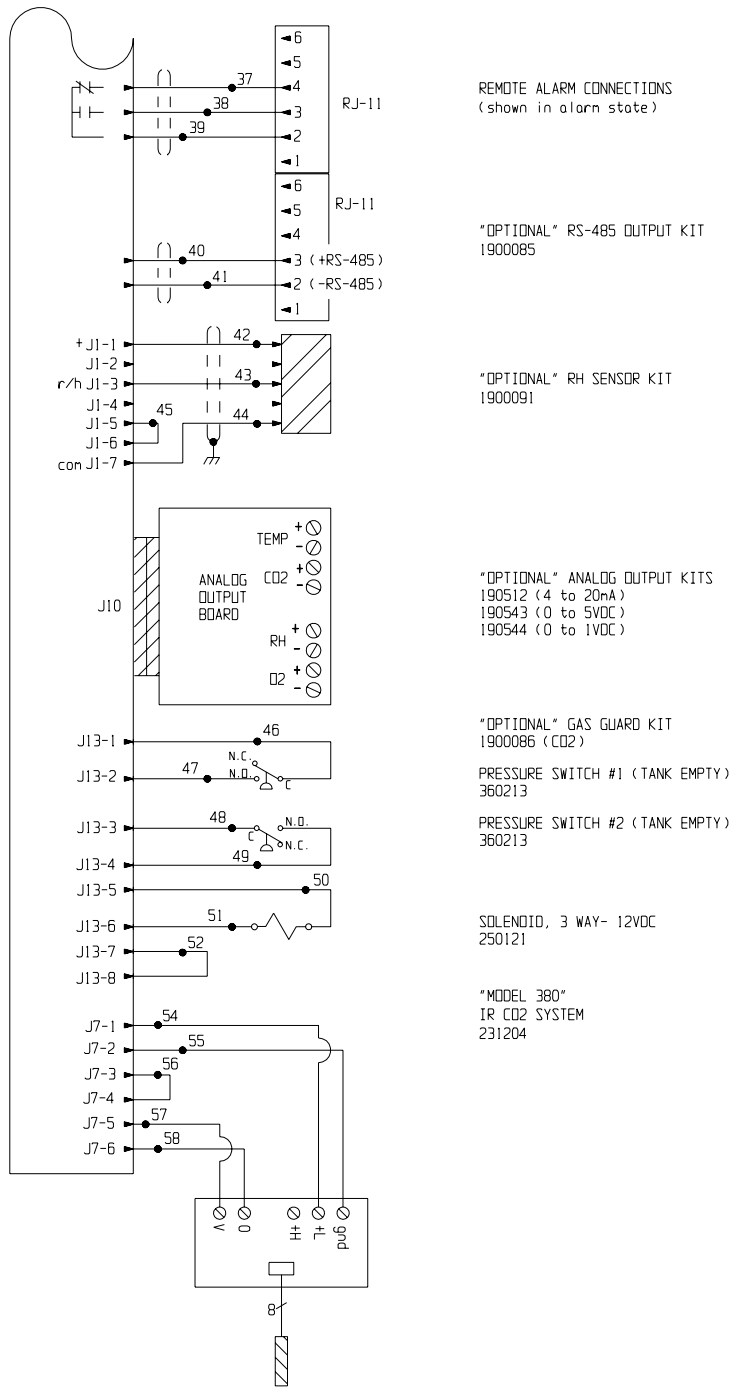

Electrical Schematic
Model:
3598, 3599, 3584,
3585, 370 and 380
Heat Sterilization
Incubators
370-70-0-D REV. 4
Page 2 of 3

77
78
79
80
81
82
83
84
85
86
87
88
89
90
91
92
93
94
95
96
97
98
99
100
101
102
103
104
105
106
107

WIRE REFERENCE CHART								
NO.	GA.	COLOR	NO.	GA.	COLOR	NO.	GA.	COLOR
1	16	BROWN	21	18	RED	42	22/3	BLACK
2	16	BLUE	22	18	GREEN	43	22/3	RED
3	16	GRN/YEL	23	18	ORANGE	44	22/3	GREEN
4	16	BLACK	24	18	GREEN	45	22	BLACK
5	16	WHITE	25	22	BLUE	46	20	RED
6	18	BLACK	26	22	BLUE	47	20	RED
7	16	YELLOW	27	22	BROWN	48	20	BLUE
8	18	ORANGE	28	22	BROWN	49	20	BLUE
9	18	RED	29	22	YELLOW	50	20	ORANGE
10	18	BLUE	30	22	YELLOW	51	20	ORANGE
11	18	RED	31	22	RED	52	20	BLACK
12	--	----	32	22	RED	53	18	BROWN
13	--	----	33	22	GREEN	54	24/4	BLACK
14	--	----	34	22	GRAY	55	24/4	WHITE
15	--	----	35	22	PURPLE	56	24	BLACK
16	--	----	36	22	ORANGE	57	24/4	RED
17	18	ORANGE	37	22/3	BLACK	58	24/4	GREEN
18	18	BLACK	38	22/3	RED	59		
19	18	YELLOW	39	22/3	WHITE	60		
20	--	----	40	22/2	RED			
			41	22/2	BLACK			

MODEL	DESCRIPTION
370	STERI CYCLE 1/C CO2 INCUBATOR
380	STERI CYCLE 1/R CO2 INCUBATOR
3598	STERI CYCLE 1/C CO2 INCUBATOR
3599	STERI CYCLE 1/R CO2 INCUBATOR
3584	STERI CYCLE 1/C CO2 INCUBATOR, RH DISPLAY
3585	STERI CYCLE 1/R CO2 INCUBATOR, RH DISPLAY

REV	ECN NO.	DATE	BY	APPD	DESCRIPTION OF REVISION
4	IN-3306	06-15-06	GJG	GJG	CCS ADDED MODEL NUMBERS
3	IN-3124	08-04-03	JNL	KDG	LON CHANGED 290137 TEMP. PROBE TO 290184
2	IN-2970	09-04-01	GLM	KDG	LON CHG. HARNESS FOR MICRO TO SENSE VOLTAGE LOSS
1	IN-2915	04-03-01	GLM	KDG	DNF CHANGED 130625 COOLING FAN TO 900135
0	N/A	1-23-01	QW	QW	DNF RELEASED PRODUCTION

Electrical Schematic
Model:
3598, 3599, 3584,
3585, 370 and 380
Heat Sterilization
Incubators



ATTENTION
OBSERVE PRECAUTIONS
ELECTROSTATIC
SENSITIVE DEVICES

THIS DOCUMENT CONTAINS PROPRIETARY INFORMATION AND SUCH INFORMATION IS NOT TO BE DISCLOSED TO OTHERS FOR ANY PURPOSE NOR USED FOR MANUFACTURING PURPOSES WITHOUT WRITTEN PERMISSION FROM THERMO ELECTRON.



MODEL/PART NAME: 370 & 380 HEAT STERILIZATION INCUBATOR

DWG TITLE: ELECTRICAL SCHEMATIC

DNW: QM CAD: QM APPD: DNF DATE: 9-12-00 SCALE: NONE

MATERIAL:

PAINTE COLOR:

TOLERANCE UNLESS OTHERWISE SPECIFIED

ANGLES: DECIMAL: .XX±1

DRAWING NUMBER
370-70-0

SIZE
0

370-70-0-D REV. 4
Page 3 of 3

THERMO ELECTRON CORPORATION DIRECT HEAT INCUBATOR WARRANTY USA*

The Warranty Period starts two weeks from the date your equipment is shipped from our facility. This allows shipping time so the warranty will go into effect at approximately the same time your equipment is delivered. The warranty protection extends to any subsequent owner during the first year warranty period.

During the first year, component parts proven to be non-conforming in materials or workmanship will be repaired or replaced at Thermo's expense, including labor. In addition, after the initial warranty period of one year the CO₂ sensor (IR) will be warranted for a second year, parts only. The CO₂ sensor (T/C) will be warranted for four additional years for a total of five years, parts only. Installation and calibration is not covered by this warranty agreement. The Technical Services Department must be contacted for warranty determination and direction prior to performance of any repairs. Expendable items, glass, filters and gaskets are excluded from this warranty.

Replacement or repair of components parts or equipment under this warranty shall not extend the warranty to either the equipment or to the component part beyond the original warranty period. The Technical Services Department must give prior approval for return of any components or equipment. At Thermo's option, all non-conforming parts must be returned to Thermo postage paid and replacement parts are shipped FOB destination.

THIS WARRANTY IS EXCLUSIVE AND IN LIEU OF ALL OTHER WARRANTIES, WHETHER WRITTEN, ORAL OR IMPLIED. NO WARRANTIES OF MERCHANTABILITY OR FITNESS FOR A PARTICULAR PURPOSE SHALL APPLY. Thermo shall not be liable for any indirect or consequential damages including, without limitation, damages relating to lost profits or loss of products.

Your local Thermo Sales Office is ready to help with comprehensive site preparation information before your equipment arrives. Printed instruction manuals carefully detail equipment installation, operation and preventative maintenance.

If equipment service is required, please call your Technical Service Department at 1-888-213-1790 (USA and Canada) or 1-740-373-4763. We're ready to answer your questions on equipment warranty, operation, maintenance, service and special applications. Outside the USA, contact your local distributor for warranty information.



Rev. 2 4/03

Thermo Electron Corporation
Controlled Environment Equipment
401 Millcreek Road
Marietta, Ohio 45750
United States

www.thermo.com